

PRIMARY APPLICATION

MERCEDES-BENZ
Sprinter 3500 4X4 (2019)

TOOLS REQUIRED

- 1 Floor Jack
- 2 Jack Stands
- 4 Wheel Blocks
- 2 9/16" wrench
- 1 9/16" socket wrench
- 1 7/32" Allen key
- 1 T50 Torx Key

PARTS LIST

Item	QTY	Part#	Description
A	2	512082	Rear T-Bracket
B	2	512083	Rear Bracket Spacer Plate
C	2	512132	Top Bracket
D	2	511415	SumoSprings (-40) blue
E	2	512131	Bottom Bracket
F	2	512021	SumoSprings Under Axle Bracket
G	4	512227	3/8" USS Flat Washer
H	6	512245	3/8" - 16 x 7/8" Flat-Head Cap Screw
I	4	512343	3/8" - 16 x 5" Hex bolt
J	2	512207	3/8" - 16 x 3/4" Serrated-Flange Bolt
K	2	512263	3/8" - 16 x 3/4" Socket Set Screw
L	1	512078	Heat Shield (Passenger Side Only)
M	1	512239	Loctite Sachet (not in diagram)

APPROXIMATE INSTALL TIME

🕒 1.5 Hours

Driver Side
(Passengers Side Similar)

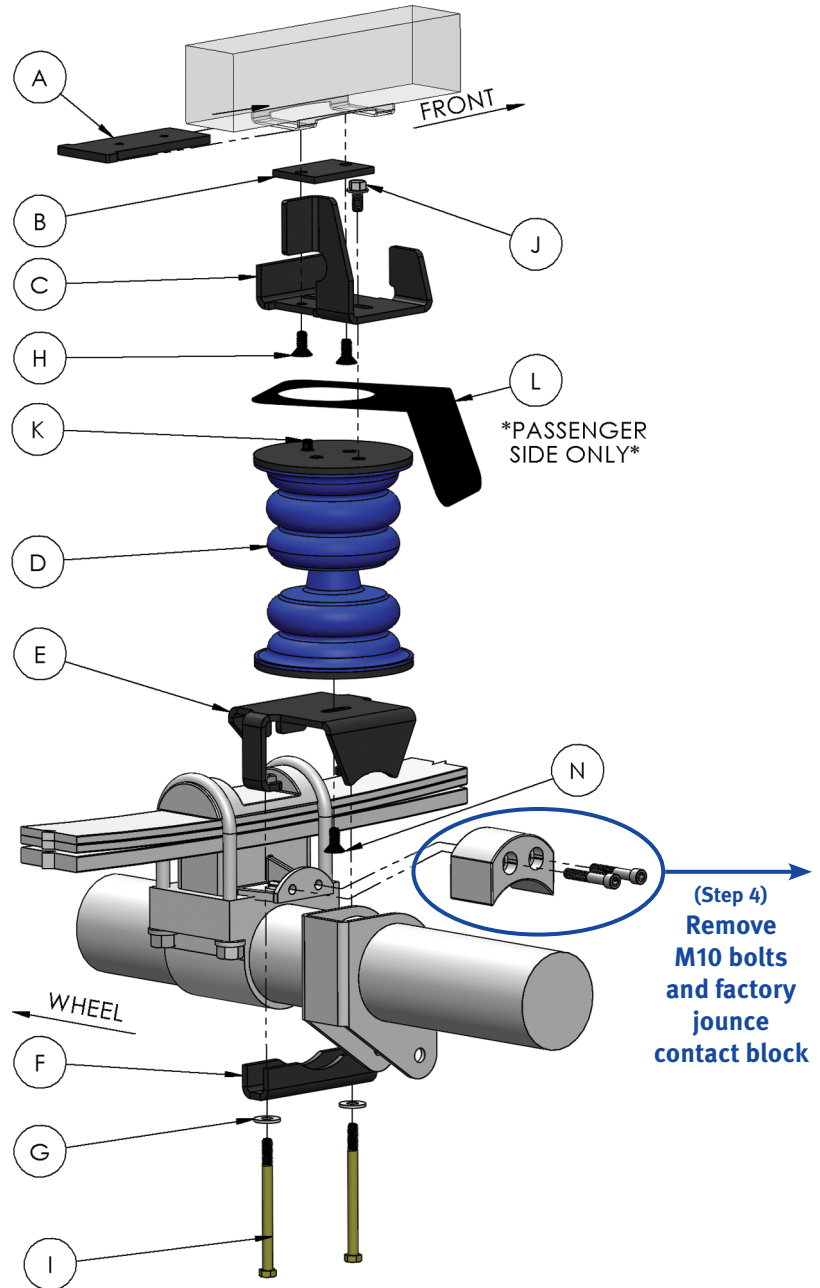

SuperSprings International, Inc.

505 Maple Avenue
Carpinteria, CA 93013

Technical Support

+1 (805) 745-5553
tech@supersprings.com

supersprings.com



Never exceed the manufacturer's Gross Vehicle Weight Rating (GVWR) located on your vehicle's identification tag.

SAFETY NOTICE: We recommend installation be done by a professional or persons with sound mechanical knowledge.

WARNING: These instructions are a general guide for installation. SuperSprings International, Inc. assumes no liability for the actual installation process. Consumers and installers should apply common automotive safety practices when raising and working on any vehicle. **Do not put yourself in a position where, if the vehicle were to move**

unexpectedly, you may be injured. SuperSprings' products are designed to improve vehicle ride quality. Do not load any vehicle beyond the manufacturer's specifications.

BEFORE INSTALLATION: Ensure the vehicle is on a level surface, the parking brake is ON, with the ignition OFF, and place blocks in front of and behind the front tires to prevent the vehicle from moving.

DURING AND/OR AFTER INSTALLATION: Ensure emergency brake cables are not touching the SuperSprings. Secure any cables out of the way with zip ties or by re-routing. **Ensure all A/C lines, brake cables and frame are clear of contact or interference.**

1. Park vehicle on a level hard surface and set wheel blocks on the front wheels to prevent rolling. Observe all safety precautions and wear safety glasses.
2. Raise the rear of the vehicle allowing the axle to hang free and rest the frame on the safety jack stands. Removing the rear wheels is optional.
3. Starting on the driver's side – remove the factory jounce bumpers from the underside of the frame and set aside. These can be removed by firmly pulling sideways and rotating them out of the holders.
4. Using a T50 Torx bit, remove the two M10 bolts that hold the factory jounce contact block to the block between the axle and leaf springs. These parts will not be reused (SEE DIAGRAM).

Remove the top bracket assembly from the box:

- ▶ **Rear T-Bracket (ITEM A),**
- ▶ **Rear Bracket Spacer Plate (ITEM B)**
- ▶ **Top Bracket (ITEM C)**

Slide the **Rear T-Bracket (ITEM A)** into the bump-stop holder bracket on the frame from the rear. Attach the **Top Bracket (ITEM C)** and the **Rear Bracket Spacer Plate (ITEM B)** to the **Rear T-Bracket (ITEM A)** using two **3/8" - 16 x 7/8" FHCS (ITEM H)**. Use the supplied loctite and secure tightly. Position the two vertical flanges on the **Top Bracket (ITEM C)** inside the frame away from the wheel.

5. Remove the bottom bracket assembly from the box:
 - ▶ **Bottom Bracket (ITEM E)**
 - ▶ **SumoSprings Under Axle Bracket (ITEM F)**

Attach the **Bottom Bracket (ITEM E)** to the bottom half of the **SumoSprings (-40) blue (ITEM D)** using a **3/8" - 16 x 7/8" FHCS (ITEM H)**. **DO NOT** apply Loctite at this stage and leave the bolt slightly loose to allow for alignment with top half of SumoSprings.

6. Locate the wider bolt pattern on the top half of the SumoSprings. Install the **3/8" - 16 x 3/4" Socket Set Screw (ITEM K)** into one of the holes so that it is sticking out 3/16 of an inch.
7. Place both halves of the SumoSprings together and set the assembly on the driver's side axle with the bottom bracket positioned as seen in the diagram on page 1.
8. Align the **3/8" - 16 x 3/4" Socket Set Screw (ITEM K)** with the outer hole of the top bracket. Bolt the top half of the SumoSprings assembly to the top bracket using one **3/8" - 16 x 3/4" Serrated-Flange Bolt (ITEM J)**. Before tightening the bolt, align the top and bottom halves of the SumoSprings.
9. After aligning the SumoSprings halves, tighten the top bolt and use a marker or scribe to mark the location of the bottom half on the bottom bracket. Remove the bottom assembly from the axle, apply Loctite to the bolt and securely fasten it in the correct position.



Never exceed the manufacturer's Gross Vehicle Weight Rating (GVWR) located on your vehicle's identification tag.

SAFETY NOTICE: We recommend installation be done by a professional or persons with sound mechanical knowledge.

WARNING: These instructions are a general guide for installation. SuperSprings International, Inc. assumes no liability for the actual installation process. Consumers and installers should apply common automotive safety practices when raising and working on any vehicle. **Do not put yourself in a position where, if the vehicle were to move**

unexpectedly, you may be injured. SuperSprings' products are designed to improve vehicle ride quality. Do not load any vehicle beyond the manufacturer's specifications.

BEFORE INSTALLATION: Ensure the vehicle is on a level surface, the parking brake is ON, with the ignition OFF, and place blocks in front of and behind the front tires to prevent the vehicle from moving.

DURING AND/OR AFTER INSTALLATION: Ensure emergency brake cables are not touching the SuperSprings. Secure any cables out of the way with zip ties or by re-routing. **Ensure all A/C lines, brake cables and frame are clear of contact or interference.**

- 10.** Attach the bottom bracket assembly to the axle using:
- ▶ **SumoSprings Under Axle Bracket** (ITEM F)
 - ▶ two **3/8" - 16 x 5" Hex bolts** (ITEM I)
 - ▶ two **3/8" USS Flat Washers** (ITEM G).

Apply Loctite to the bolt threads and tighten securely but take care not to over tighten and bend the bottom SumoSprings bracket.

- 11.** Repeat steps three through ten on the passenger's side of the vehicle. Be sure to install the exhaust **heat shield** (ITEM L) between the top bracket and SumoSprings and position accordingly.
- 12.** If rear wheels were removed you can now reinstall the rear wheels.
- 13.** Jack up vehicle, remove safety jack stands and carefully lower the vehicle to the hard surface.
- 14.** Remove wheel blocks from the front wheels.
- 15.** Fill out warranty information at: supersprings.com/warranty/

SuperSprings International, Inc.

505 Maple Avenue
Carpinteria, CA 93013

Technical Support

+1 (805) 745-5553
tech@supersprings.com

supersprings.com



Never exceed the manufacturer's Gross Vehicle Weight Rating (GVWR) located on your vehicle's identification tag.

SAFETY NOTICE: We recommend installation be done by a professional or persons with sound mechanical knowledge.

WARNING: These instructions are a general guide for installation. SuperSprings International, Inc. assumes no liability for the actual installation process. Consumers and installers should apply common automotive safety practices when raising and working on any vehicle. **Do not put yourself in a position where, if the vehicle were to move**

unexpectedly, you may be injured. SuperSprings' products are designed to improve vehicle ride quality. Do not load any vehicle beyond the manufacturer's specifications.

BEFORE INSTALLATION: Ensure the vehicle is on a level surface, the parking brake is ON, with the ignition OFF, and place blocks in front of and behind the front tires to prevent the vehicle from moving.

DURING AND/OR AFTER INSTALLATION: Ensure emergency brake cables are not touching the SuperSprings. Secure any cables out of the way with zip ties or by re-routing. **Ensure all A/C lines, brake cables and frame are clear of contact or interference.**