

## INSTALLATION INSTRUCTIONS

**DOMINATOR III Series SideSteps Part Number D36040 (B-PS)**

**2011 Chevrolet Silverado / GMC Sierra 2500HD, 3500HD Extended Cab P/U 2/4WD Short Bed (Diesel)**

Do not attempt to install this product on any vehicle other than the one it is designed for and listed above!

### Parts List

<u>QTY</u>	<u>Part Description</u>	<u>QTY</u>	<u>Part Description</u>
11	5/16" U-Nut	13	3/8" Hex Nut
11	5/16" x 1" Hex Bolt	1	C0912 Passenger Front Bracket
11	5/16" Flat Washer	2	C0922B Passenger Center & Rear Bracket
11	5/16" Lock Washer	3	C0921B Driver Front, Center & Rear Bracket
1	3/8" T-Bolt	1	Vinyl Gasket
12	3/8" x 1 1/4" Hex Bolt	1	340FP Passenger Side Step Front Section
13	3/8" Lock Washer	1	340RP Passenger Side Step Rear Section
25	3/8" Flat Washer	1	340FD Driver Side Step Front Section
		1	340RD Driver Side Step Rear Section

### **Tool Required:**

1/2" & 9/16" Sockets  
 1/2" & 9/16" Wrenches  
 3/16" Hex Key  
 Ratchet & Ratchet Extension

**Approximate installation time: 45min**

### Installation

**Read the installation instructions completely and verify that all of the parts listed are accounted for.**

**Step-1** This installation uses three mounting brackets per side. Begin by installing the passenger side front bracket. Measure from the front fender bolt rearward approximately 14", locate the hole in the body pinch mold and install (1) 5/16" U-Nut as shown. **Photo #1 & #2**

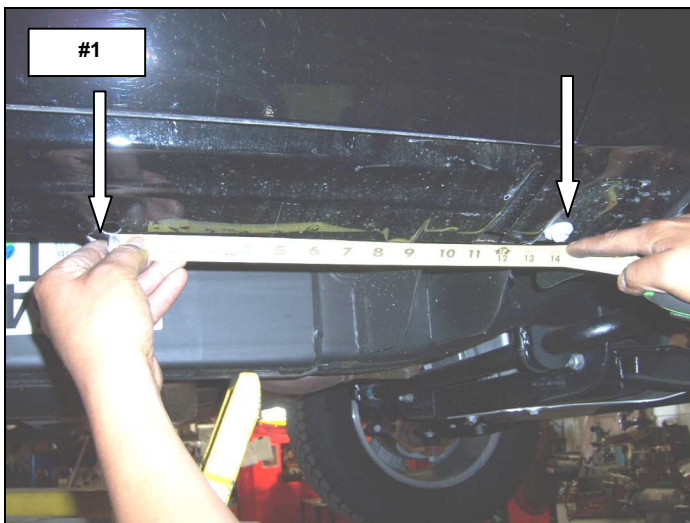

**Step-2** Locate in front of the urea tank the plastic plug in the body rocker panel. Remove the plug, Install the vinyl gasket over the threads of the 3/8" T-Bolt and install T-Bolt in the rocker panel as shown. **Photo #3 & #4**

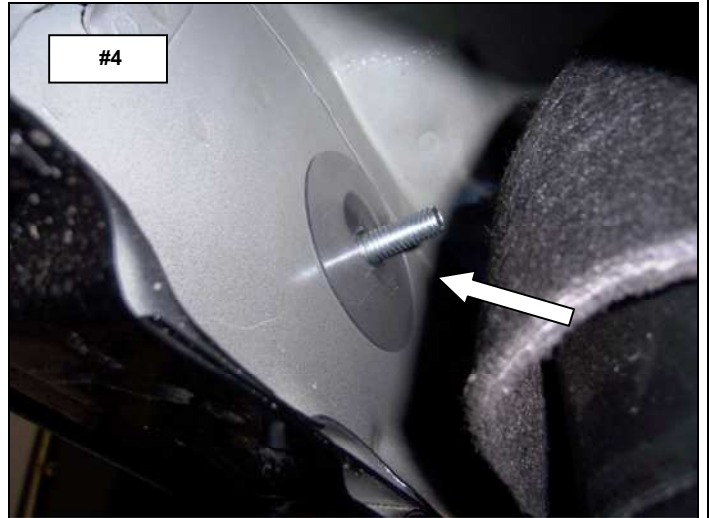
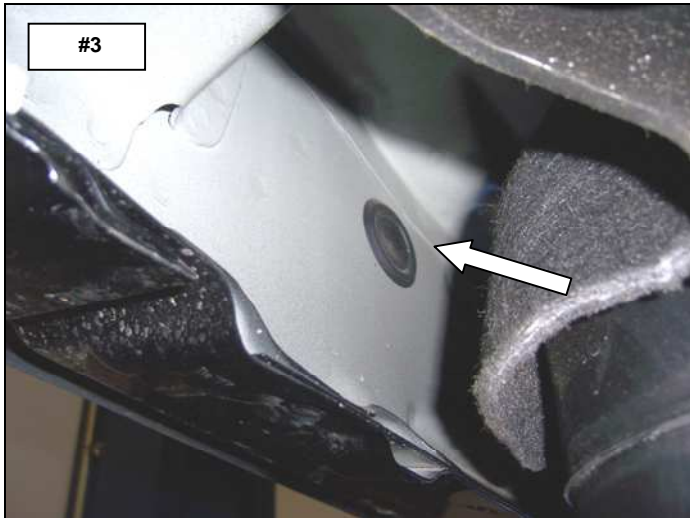

**Step-3** From the front of the urea tank, position the front mounting bracket between the tank and the body pinch mold. Slide the bracket rearward and align the holes in the bracket with the T-Bolt and U-Nut. **Photo #5 & #6**



**Step-4** Position the hole in the front of the bracket over the T-Bolt and install (1) 3/8" flat washer, (1) 3/8" lock washer and (1) 3/8" hex nut. Align the hole in the flange of the bracket with the U-Nut and install (1) 5/16" flat washer, (1) 5/16" lock washer and (1) 5/16" x 1" hex bolt. Leave the nut and bolt loose for final adjustment. **Photo #7 & #8**

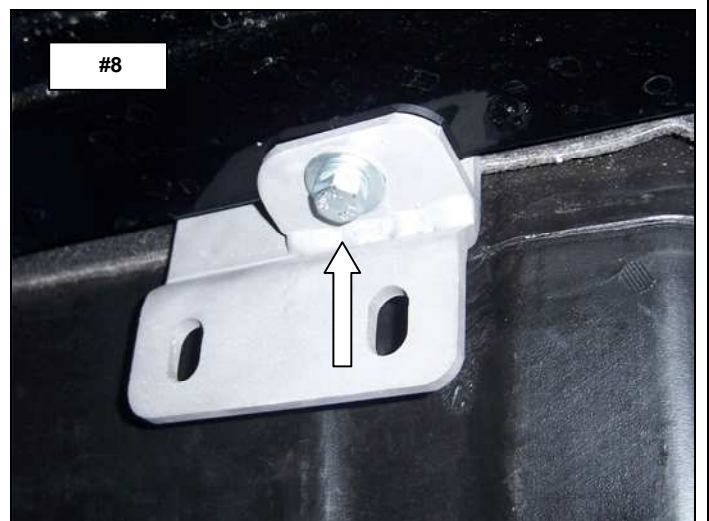

**Step-5** Passenger side Center bracket installation.

Measure from the front fender bolt rearward approximately 49 5/8" and locate the hole in the body pinch mold and the plastic plug in the rocker panel. Remove the plastic plug from the rocker panel and install 5/16" U-Nuts in the rocker panel and pinch mold. Attach one of the C0922B brackets to the rocker panel and pinch mold using the (2) 5/16" x 1" hex bolts, (2) 5/16" lock washers and (2) 5/16" flat washers. Leave the bolts loose for final adjustment.

**Photo #9 & #10**

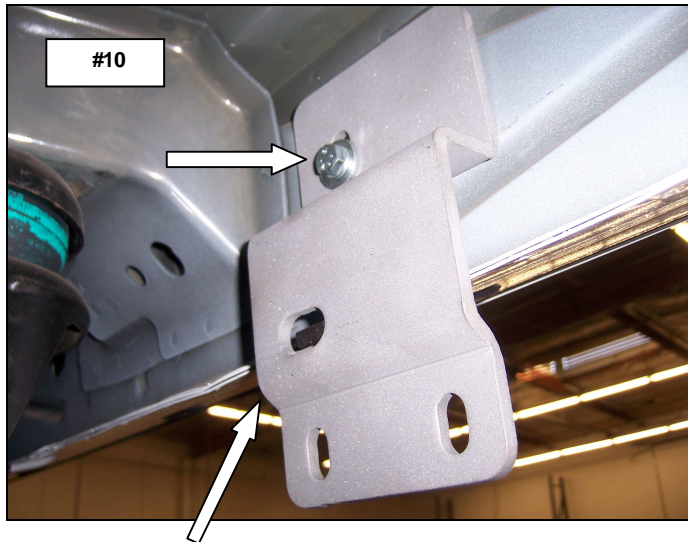
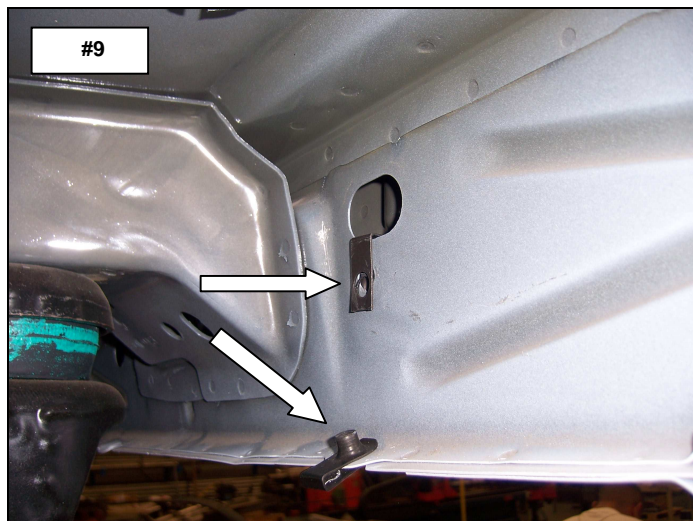

**Step-6** Passenger side rear bracket installation.

Measure from the front fender bolt rearward approximately 67" and repeat step 5 to install the remaining C0922B bracket.

**Step-7** Attach the passenger side step to the front bracket **Photo #11** and to the center and rear bracket **Photo#12** using (2) 3/8" x 1 1/4" hex bolts, (4) 3/8" flat washers, (2) 3/8" lock washers and (2) 3/8" hex nuts for each bracket.

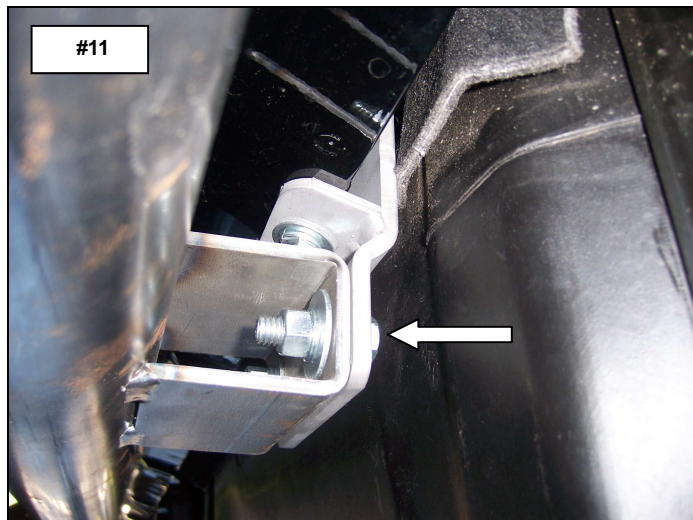

**Step-8** Align the side step with the vehicle and tighten all nuts and bolts.

**Step-9** Driver side bracket installation.

Measure from the front fender bolt rearward approximately 14" and locate the hole in the body pinch mold and the plastic plug in the rocker panel. Remove the plastic plug from the rocker panel and install 5/16" U-Nuts in the rocker panel and pinch mold. Attach one of the C0921B brackets to the rocker panel and pinch mold using the (2) 5/16" x 1" hex bolts, (2) 5/16" lock washers and (2) 5/16" flat washers. Leave the bolts loose for final adjustment.

**Photo #13 & #14**

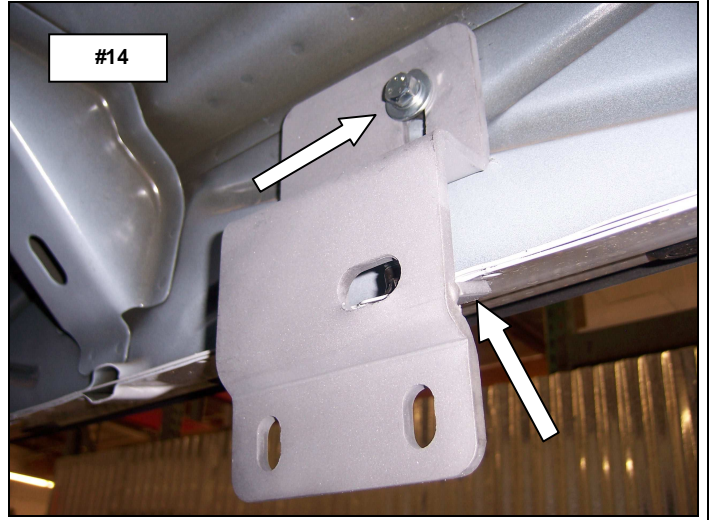
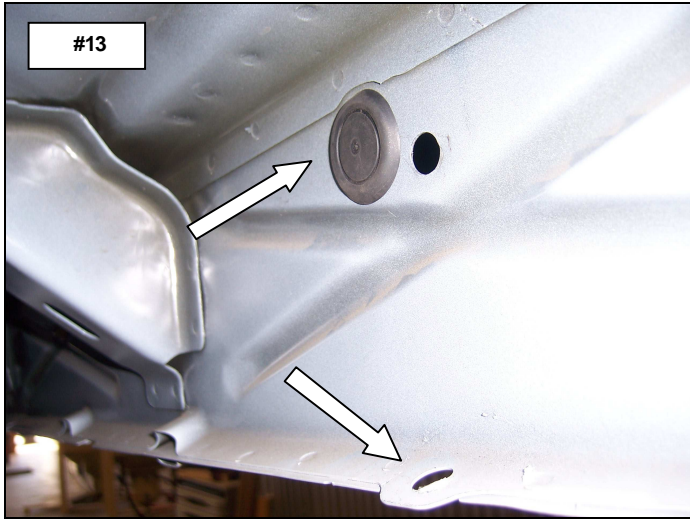

**Step-10** Driver side center and rear brackets.

Repeat steps 5 through 7 to install the driver side center bracket, rear bracket and side step. Align the side step with the vehicle and tighten all nuts and bolts.

**Remember to check and retighten all nuts and bolts periodically.**



**Please do not return this product to place of purchase.**

**If you have defective, missing or damaged parts or need assistance, please contact *Go Rhino Products* for fast, friendly customer service at: 1-800-731-0425 or email: [info@gorhino.com](mailto:info@gorhino.com)**

# SIDE BAR WHEEL TO WHEEL

## ASSEMBLY INSTRUCTIONS

QTY	PARTS DESCRIPTION
2	PLASTIC PLUGS
2	3/8" X 3/4" SOCKET SET SCREWS
2	PLASTIC TRIM RINGS

**STEP 1.** BEGIN BY LAYING OUT THE DRIVER SIDE FRONT AND REAR SIDESTEP SECTIONS ON A PROTECTIVE SURFACE WITH THE STEP PAD SIDE DOWN.

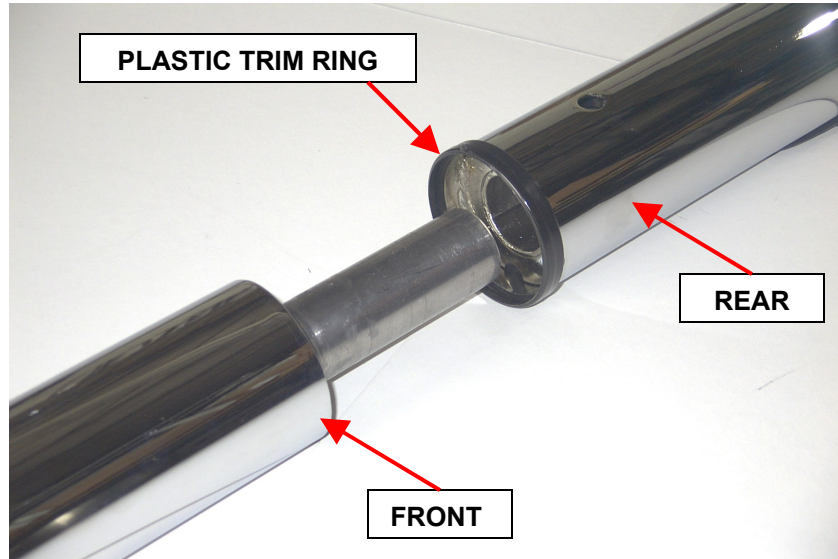

**STEP 2.** INSTALL THE PLASTIC TRIM RING ON THE REAR SECTION AND INSERT THE FRONT SECTION INTO THE REAR SECTION.

**STEP 3.** POSITION THE SIDESTEP SECTIONS AGAINST THE PLASTIC TRIM RING.

**STEP 4.** ALIGN THE FRONT AND REAR STEP HOOPS AND SECURE THE ASSEMBLY USING (1) SOCKET SET SCREW.

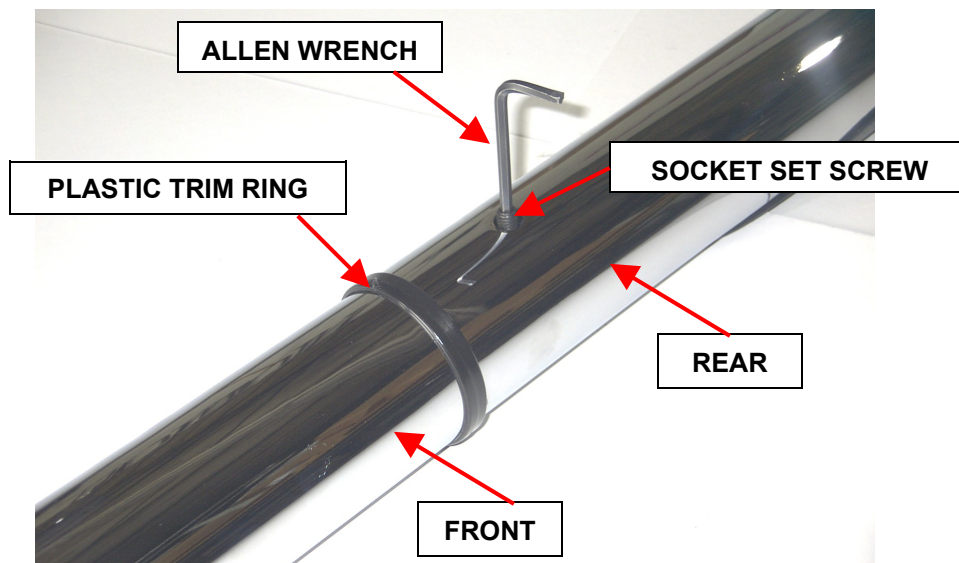

**STEP 5.** INSTALL THE PLASTIC PLUG TO CONSEAL THE SET SCREW.

REPEAT THE ABOVE STEPS TO ASSEMBLE THE PASSENGER SIDE.

FODI7.003.I