

INSTALLATION INSTRUCTIONS

4444 (1 - 2 - 3 - 4)

Toyota Highlander 2003 - 2005

Parts List:

QTY	(1) Hardware kit including:
(1) Sidebar set	(2) 1/2" flat washer
(1) Front brackets set	(2) 1/2" lock nut
(1) Rear brackets set	(8) 3/8 X 1 1/2" hex. Head bolt
(1) Front support bracket A	(28) 3/8" flat washer
(1) Front support bracket B	(20) 3/8" lock washer
(2) Special Bolt A 3/8 x 1 1/2"	(12) 3/8" hex. nut
(2) Special Bolt B 1/2 x 1 1/2"	(10) 3/8 X 1" hex. Head bolt
(2) Special Bolt C 3/8 x 1 1/4"	
(2) Complement bracket set	

Tools required:

9/16" Wrench	9/16" Socket	Ratchet	Extension to ratchet
3/4" Wrench	3/4" Socket		

Instructions:

Approximated installation time: 40 min.

1. Read and understand instructions completely before beginning installation.
2. Refer to illustration 1 to identify the driver and passenger side mounting brackets.
3. The front mounting brackets mount to the factory locations on the body panel underneath the vehicle using the 3/8 x 1 1/2" special bolts A as shown in illustration 1 & 2.
4. Insert the Special Bolt A through the large opening on the body panel and then fasten (Hand tighten) the mounting bracket as shown in illustration 2. Using 3/8" flat and lock washers and 3/8" hex nut.
5. The rear bracket also mounts to the body panel, fasten (Hand tighten) the rear-mounting bracket using the special bolt B, 1/2" flat washer and lock nut as shown in illustration 2.
6. Attach the complement bracket on the front and rear brackets with: 3/8" hex head bolt, 3/8" flat and lock washers and 3/8" hex nut.
7. Align the driver side tube step to the brackets and fasten (Hand tight) using the 3/8" hex. head bolts with their corresponding flat and lock washers as shown in the illustrations.
8. Align the driver side front support bracket (it is the longest) to the mounting bracket as shown in illustration 2, locate and insert the Special Bolt C, through the body panel opening that lines up with the support bracket. Fasten (Hand tight only) that end of the support bracket A using the 3/8" flat washers and hex. nuts supplied.
9. Fasten the other end of the front support bracket A the hole on the mounting bracket as shown in illustration 2, using a 3/8" bolt, 2 flat washers and hex. nuts.
11. Finally align the tube step to the desired position and tighten all of the hardware.
12. Repeats steps 3 - 9 to install the passenger side tube step.
13. You may need to periodically re-tighten the fasteners on your sidebar.

Assembly Diagram:

ILLUSTRATION 1

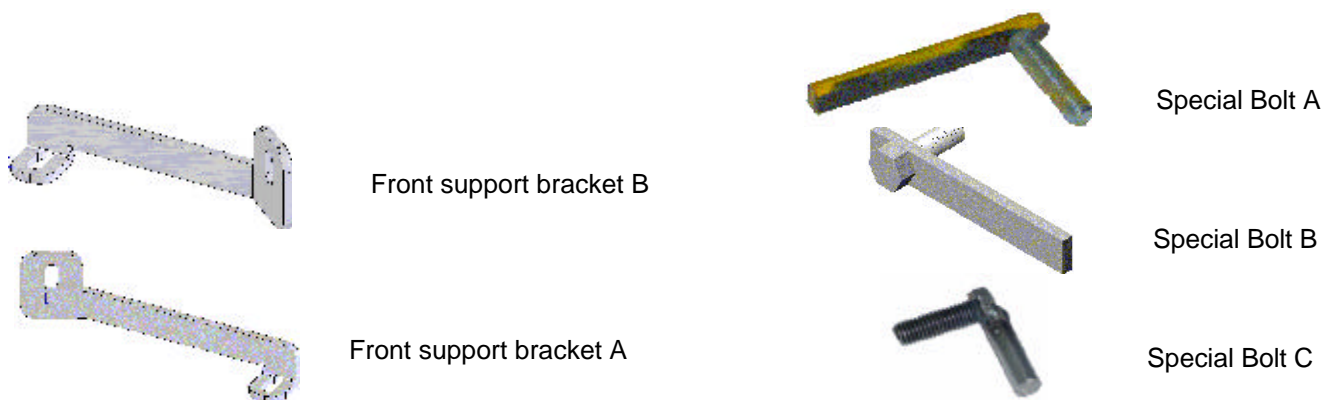

Cleaning and care instructions:

Diseño:

Calidad:

Protect the finish with a non-abrasive automotive wax, (e.g. Pure Carnauba) on a regular basis. The use of any soap, polish, or wax that contains an abrasive is detrimental to the finish, as the compounds scratch the finish and cause corrosion.

INSTALLATION INSTRUCTIONS

4444

ILLUSTRATION 2

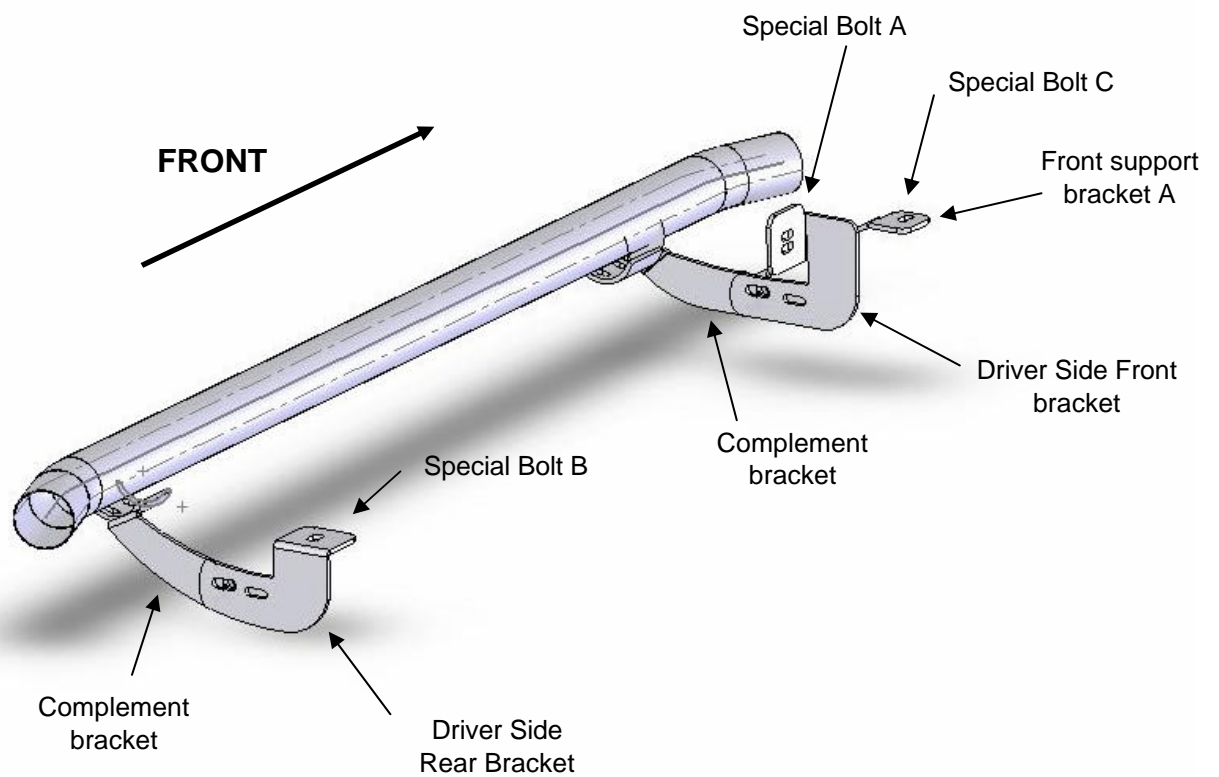

Illustration driver side.

Cleaning and care instructions:

Protect the finish with a non-abrasive automotive wax, (e.g. Pure Carnauba) on a regular basis. The use of any soap, polish, or wax that contains an abrasive is detrimental to the finish, as the compounds scratch the finish and cause corrosion.

Diseño:

Calidad: