

INSTALLATION INSTRUCTIONS

BRK

GMC TERRAIN / CHEVROLET EQUINOX

6840685

2012

PARTS LIST

Item	Qty.	Code	Description	Torque
1	2	391700AA	FRONT BRACKET	
2	1	391700BA	REAR BRACKET SET.	
3	2	-	3/8" BOLT PLATE	
4	2	-	M10 ROUND BAR BOLT	
	1	KTE-391705	HARDWARE KIT	
5	4	-	3/8 " FLAT WASHER	
6	4	-	3/8" LOCK WASHER	
7	2	-	3/8" HEX NUT	
8	2	-	M10 HEX NUT	
9	8	-	5/16 X15/16" SQUARE HEAD BLACK BOLT	
10	8	-	5/16" FLAT BLACK WASHER	
11	8	-	5/16" LOCK BLACK WASHER	

TOOL REQUIRED:

A. RATCHET

B. SOCKET: 9/16"

C. WRENCH: 9/16"

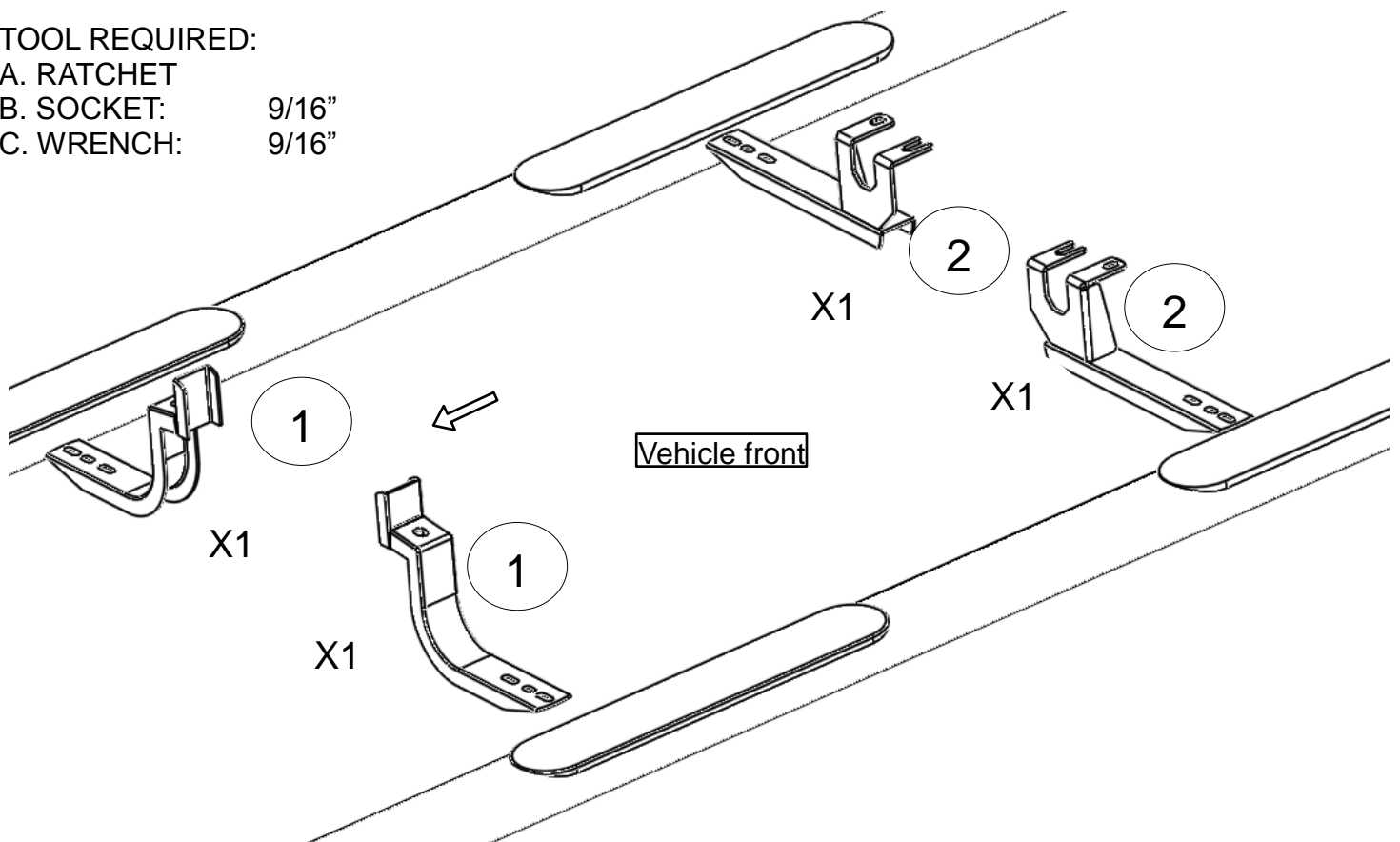

1. Before beginning the installation read all instructions carefully and verify that all the hardware is accounted for. If there are any listed part missing please notify your distributor immediately.

2. To maintain and care this product keep it clean and do not use abrasive cleaners or polish waxes. We recommend to use only non-abrasive automotive wax such as pure carnauba to avoid scratches and rust.

3. The approximated installation time is 40 min.

4. Locate the holes under the vehicle where the bracket will be installed. pic 2



5. Insert a 3/8" bolt plate into the hole under the front door. Fix the bracket with a 3/8" lock and flat washer and a 3/8" silver hex nut. Fix the bracket among the rocket panel of the vehicle. (pic 3 y 4)

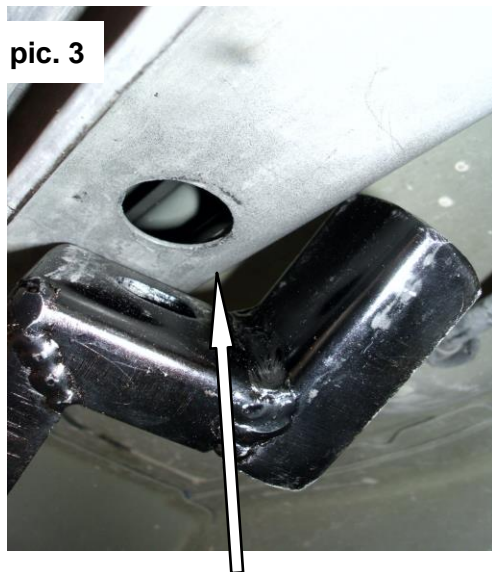

Hole / 3/8 " bolt plate

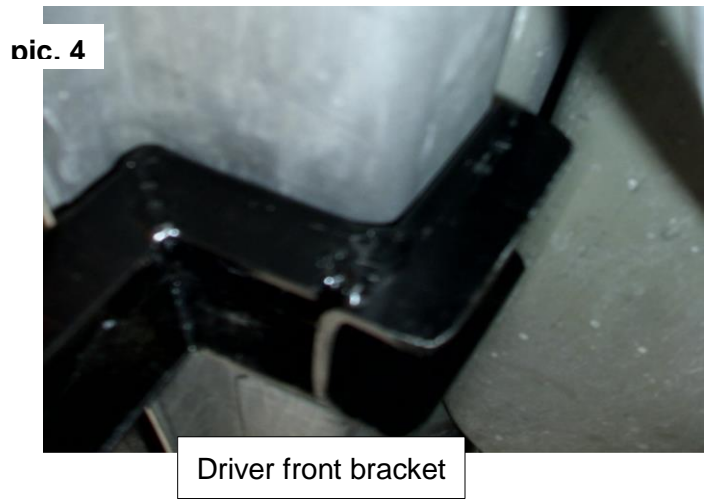

6. Insert a M10 round bar bolt by the side hole near to the suspension and place it into the shown hole. Untight the suspension bolt just enough to slide the bracket into position. **NOTE: Do not remove the suspension bolt.** Secure the bracket with the suspension bolt and the round bar bolt use a 3/8" flat and lock washers and a M10 Hex nut. Do not tight yet.
(pic. 5 y 6)

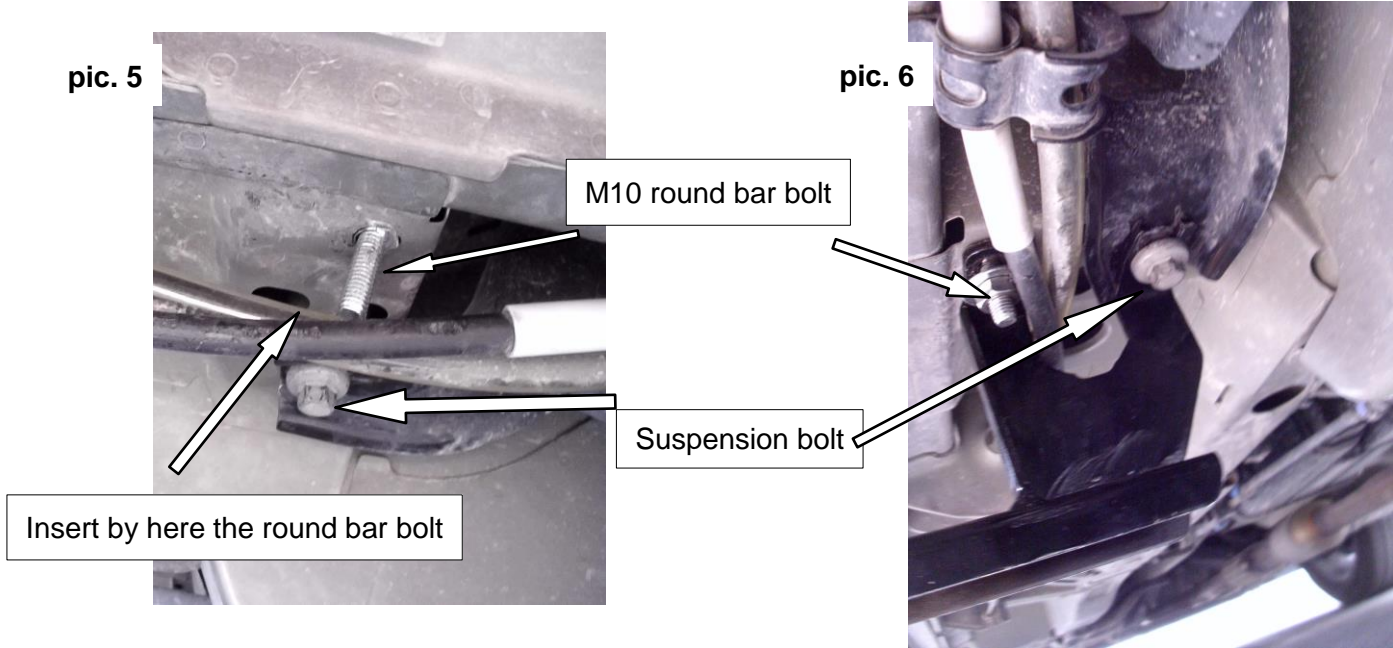

7. Place the side bar on the installed brackets and attach whit "U" bracket from the side bar hardware kit. Attach whit 5/16" square head bolts, 5/16" flat and lock black washers. (PIC 8)

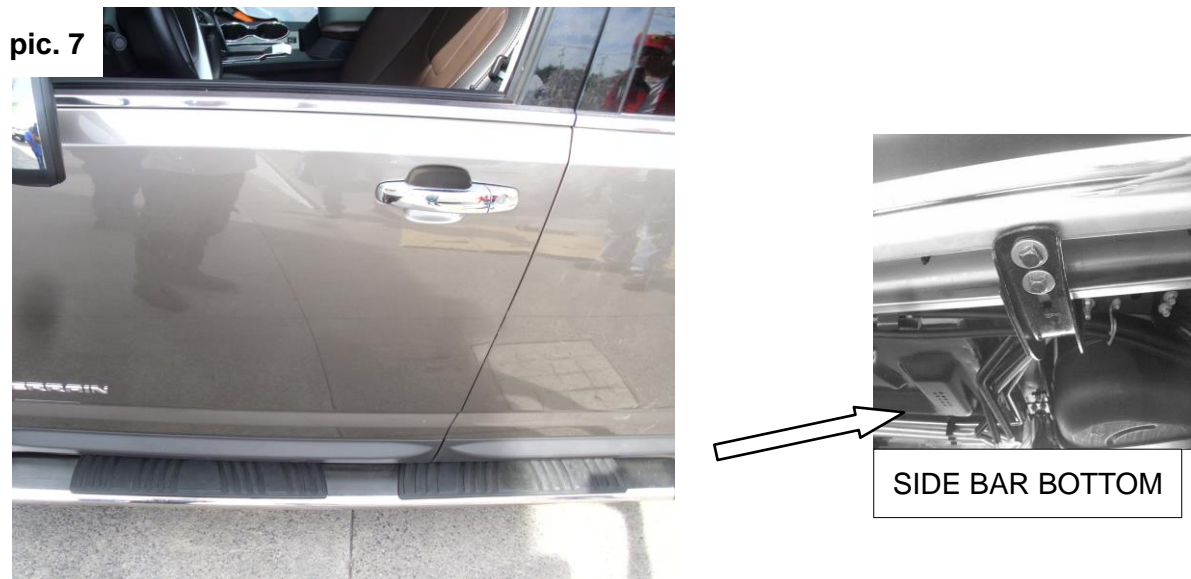

8. Align the side bar and tight all the hardware