



INSTALLATION INSTRUCTIONS

2014+ Chevy Colorado/GMC Canyon Crew-Cab Under Rear-Seat Lockbox #343

Please read and fill out the enclosed warranty registration card or register online at tuffyparts.com/warrantyreg.aspx to activate your warranty.



Underseat Lockbox #343

PARTS CHECKLIST



#16 (1) Mounting Bracket (Left)

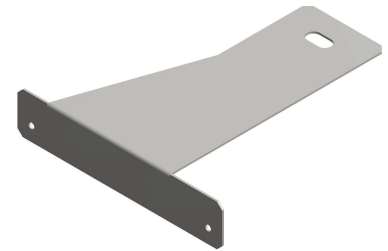

#15 (1) Mounting Bracket (Right)

SHIPPING PACKAGE CHECKLIST



#13.1 (2) M10x45mm Cap Screw



#13.2 (2) 3/8" Flat Washer



#13.3 (4) #6-32x1/2" Cap Screw

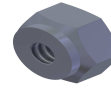

#13.4 (4) #6-32 Nylock Nut



#13.5 (4) #6 Flat Washer

Tools needed for standard installation

•8mm Socket •10mm Socket •13mm Socket •T47 Torx Wrench •5/16 Socket •5/64" Hex Wrench

PLEASE READ ALL INSTRUCTIONS THOROUGHLY BEFORE STARTING INSTALLATION.

1. Remove all contents from the shipping box and confirm that all the components listed above are present.
2. Assemble the rear mounting brackets (#15 and #16) to the enclosure using (4) #13.3 Screws, (4) #13.5 Washers, and (4) #13.4 Nylock Nuts (Shown in Figure 1).

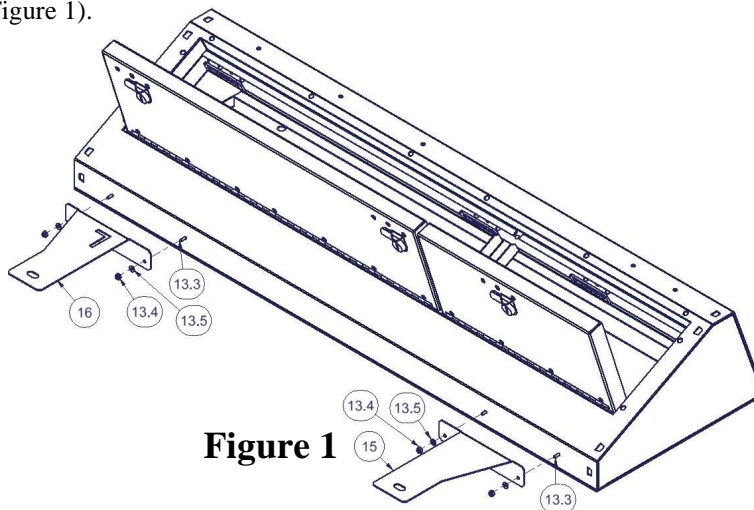

Figure 1

3. Lift both rear seats so they are secured in the upright position.
4. Remove the (7) Factory Rubber Bumpers from the top of the plastic storage enclosure. Five (5) are located at the top of the plastic enclosure, and two (2) are found at the rear on either side, near the rear mounting points. **NOTE:** The five (5) on top will be reused on the #343 Lockbox.
5. Remove the (4) Factory Plastic Carpet Anchors (located in the small cubbies on the left and right side of the plastic enclosure) from the carpet by applying upwards pressure, while unscrewing them. **NOTE:** These parts cannot be separated from the plastic enclosure and attempting to do so will damage them.
6. Lift the plastic enclosure off the metal support structure and set aside.
7. Remove the rear mounting nuts off the studs that hold the factory metal supports. **NOTE:** These nuts will be reused.
8. Remove the forward mounting bolts near the vertical support legs. **NOTE:** These bolts will not be reused but should be saved for future replacement of Factory Enclosure if so desired.
9. Place the assembled #343 Lockbox on the floor of the vehicle with the mounting brackets toward the rear of the vehicle. **Note:** The enclosure is quite heavy, and it is easier to have a second person for this step.
10. Slide the enclosure into position with the holes in the #15 and #16 Rear Mounting Brackets over the rear mounting studs.
11. Replace, but do not tighten the Factory Rear Mounting Nuts removed in Step #7.
12. Install, but do not tighten (2) #13.1 Cap Screws, and (2) #13.2 Flat Washers at the front of the #343 Enclosure. **Note:** Shown in Figure 2(Lids removed for clarity).

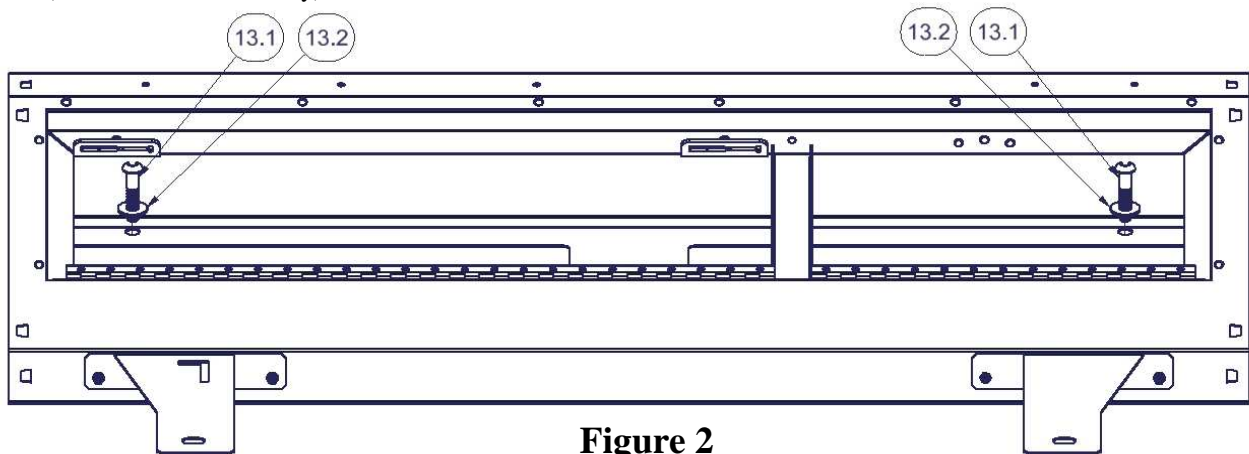

Figure 2

13. Center the enclosure over all the mounting points and tighten the mounting hardware.
14. Reinstall (5) of the Factory Rubber Bumpers (removed in Step #4) using the factory hardware.

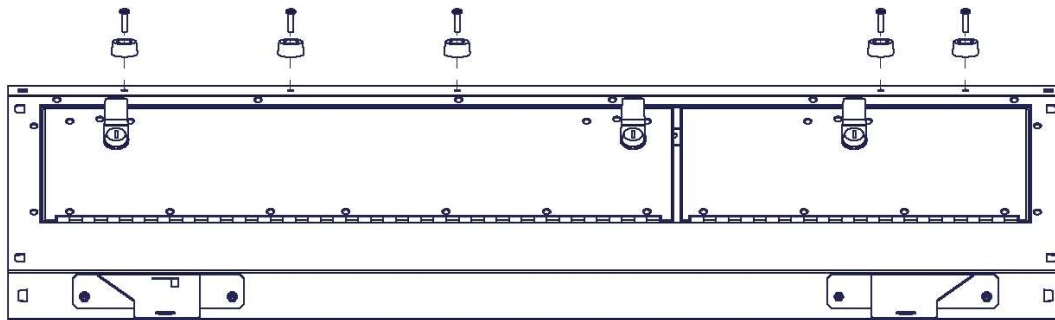

Figure 3

Call (800)348-8339 for Technical Support