

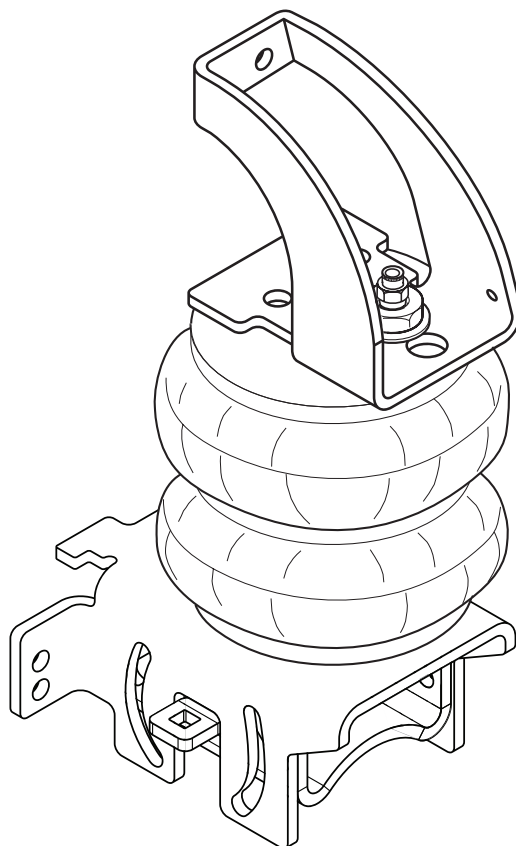

riderite.com

# INSTALLATION INSTRUCTIONS



**Firestone**

*World's Number 1  
Air Spring.*



FIRESTONE INDUSTRIAL PRODUCTS COMPANY

# ! IMPORTANT

*PLEASE DON'T HURT YOURSELF, YOUR KIT OR YOUR VEHICLE. TAKE A MINUTE TO READ THIS IMPORTANT INFORMATION.*

**DO NOT INSTALL IF THE TRUCK HAS BEEN LIFTED AND THE STOCK JOUNCE BUMPER SPACERS ARE NOT ON THE VEHICLE.** *This kit is to be used on a **pickup truck only**, and **DOES NOT INCREASE YOUR VEHICLE'S MAXIMUM LOAD.***

## **SAFE INSTALLATION**

Please take all safety precautions during installation. A hydraulic jack can fail, and if that happens, you can be seriously hurt, or worse, if you are relying on it to hold up the vehicle. If you use a hydraulic jack, secure jack stands in the appropriate locations and chock any tires still touching the ground.

Wear safety glasses or goggles. Your eyes may be lower than some parts and pieces, and you don't want to lose an eye.

Remove the possibility of any electrical issues by disconnecting the negative battery cable.

## **KIT CLEARANCE**

There must be a minimum of 1/2" clearance around all installed components when the Air Springs are inflated and under a load. The Air Springs must flex and expand during operation, so the clearance keeps the kit from rubbing against parts of the vehicle.

## **VEHICLE GVWR**

NEVER exceed the maximum load recommended by the vehicle manufacturer (GVWR). The GVWR can be found in your vehicle's owner's manual or on the data plate on the driver's side door.

## **INFLATING THE AIR SPRINGS**

When inflating Air Springs, add air pressure in small quantities, checking air pressure frequently. The Air Springs have much less air volume than a tire, so they inflate much more quickly.

## **PRESSURE TO LOAD**

The Air Springs will support approximately 50 lbs. of load for each PSI of inflation pressure (per pair). For example, 50 PSI of inflation pressure will support a load of 2500 lbs. per pair of Air Springs.

## **APPROPRIATE AIR PRESSURE**

For best ride, use only enough air pressure in the Air Springs to level the vehicle when viewed from the side (front to rear). This will vary, depending on the load, location of the load, condition of the existing suspension, and personal preference.

## **OPTIONAL T-FITTING**

This kit includes Inflation Valves and Air Line Tube for each Air Spring, allowing you to compensate for unbalanced loads. If you prefer a single Inflation Valve system to provide equal pressure to both Air Springs, your dealer can supply the optional "T" fitting (Part # 3025 or WRI-760-3461 retail pack).



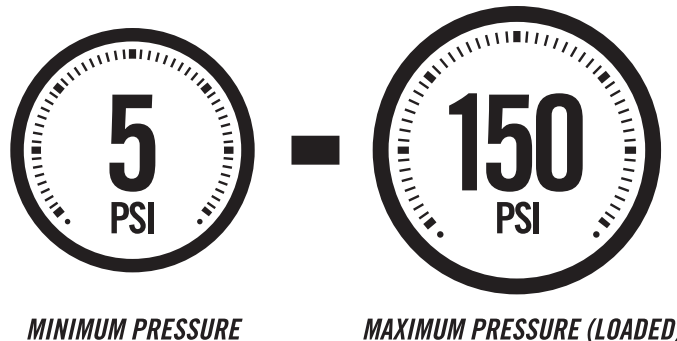



**ONCE INSTALLED SUCCESSFULLY, FOLLOW THESE PRESSURE REQUIREMENTS FOR THE AIR SPRINGS:**



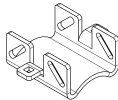
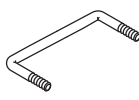
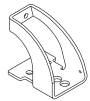
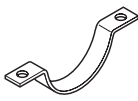

# PARTS

Compare the parts below to your kit. Assure you have all pieces, and organize them for an easier installation.















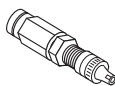



## MAIN KIT CONTENTS

PART # 8401	 x2 AIR SPRING	PART # 5845	 x2 SADDLE BRACKET	PART # 3077	 x2 BAIL CLAMP
PART # 5839	 x1 LEFT SIDE UPPER BRACKET	PART # 1163	 x2 AXLE STRAP BRACKET	PART # 1004	 x1 HEAT SHIELD
PART # 5827	 x1 RIGHT SIDE UPPER BRACKET	PART # 5664	 x4 1/2" SPACER	PART # 9153	 x1 AIR LINE TUBE (30 FEET)
PART # 5843	 x2 LOWER BRACKET	PART # 5750	 x4 1/4" SPACER		

## A24-760-7560 INFLATION VALVE BRACKET KIT

PART # 9483	 x1 NO-DRILL INFLATION VALVE BRACKET	PART # 9488	 x2 LARGE NYLON TIE
-------------	--	-------------	---

## A21-760-2703 HARDWARE PACK

PT # 3029	 x1 3/8" - 16 x 1 1/2" HEX HEAD BOLT	PT # 3488	 x19 3/8" - 16 NYLOCK NUT	PT # 3478	 x1 3/4" LOCK WASHER
PT # 3493	 x20 3/8" FLAT WASHER (Use as necessary with 3/8" Nylock Nuts)	PT # 0532	 x2 3/8" LARGE FLAT WASHER	PT # 3032	 x2 INFLATION VALVE AND VALVE CAP ASSEMBLY
PT # 3033	 x4 5/16" FLAT WASHER	PT # 3494	 x1 3/4" - 16 x 1 3/4" HEX HEAD BOLT	PT # 3046	 x2 AIR FITTING
PT # 3142	 x2 3/8" - 16 x 5/8" FLAT HEAD BOLT	PT # 3485	 x2 3/4" - 16 HEX NUT	PT # 3481	 x4 3/8" - 16 x 3" CARRIAGE BOLT
PT # 3479	 x1 3/4" THICK WASHER	PT # 3412	 x1 3/4" - 16 FRAME NUT	PT # 9168	 x6 BLACK NYLON TIE
PT # 3338	 x8 3/8" - 16 x 1" HEX HEAD BOLT	PT # 3064	 x2 INTERNAL TOOTH LOCK WASHER	PT # 0899	 x2 THERMAL SLEEVE
PT # 3345	 x2 3/8" - 16 x 2 1/2" FLAT HEAD BOLT	PT # 3480	 x1 3/4" FLAT WASHER		

# CONTENTS AND OVERVIEW

PAGE **4** REMOVE JOUNCE BUMPER & INSTALL UPPER BRACKET

PAGE **5** FASTEN AIR SPRING TO UPPER BRACKET

PAGE **6** INSTALL LOWER BRACKET ASSEMBLY

PAGE **7** SECURE LOWER BRACKET

PAGE **8** INSTALL RIGHT SIDE UPPER BRACKET

PAGE **9** HEAT SHIELD & PASSENGER SIDE

PAGE **10** AIR LINE TUBE & INFLATION VALVE INSTALLATION

PAGE **11** INSTALL & ROUTE AIR LINE TUBE

PAGE **12** CHECKING THE SYSTEM

PAGE **13** FIXING AN AIR LEAK

PAGE **14** FINISHING THE INSTALLATION

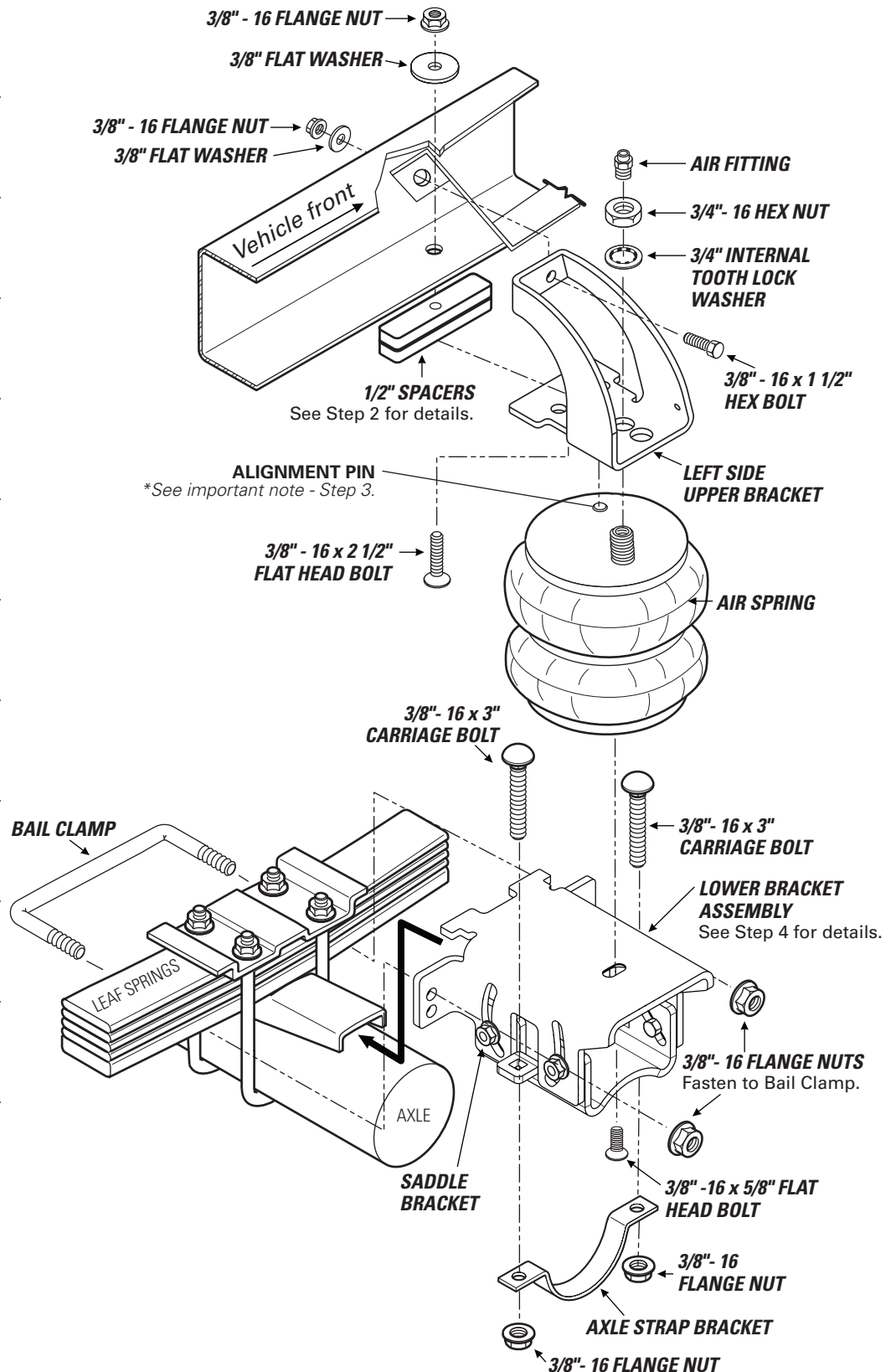

REMOVE EXISTING JOUNCE BUMPER & UREA TANK BOLT AND CLIP

1



THIS STEP IS FOR DIESEL TRUCKS ONLY.

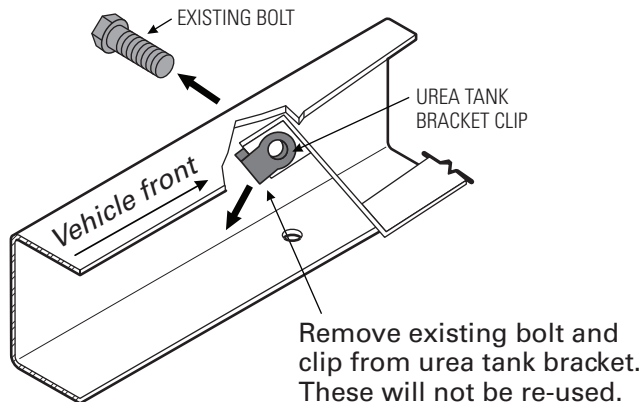
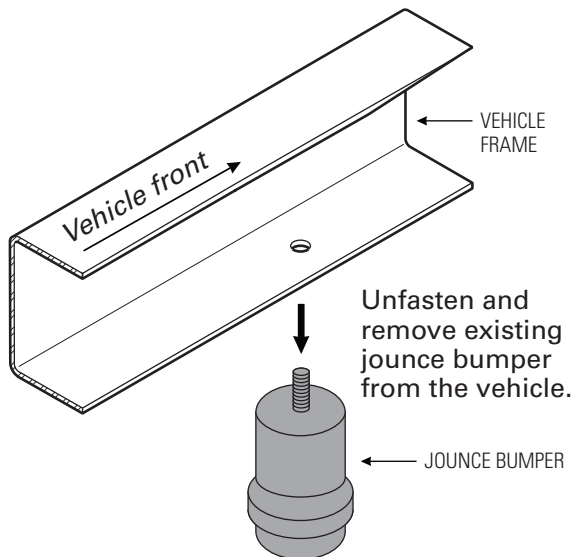

INSTALL LEFT SIDE UPPER BRACKET

2

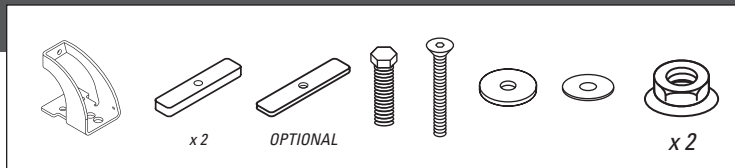

ASSURE NO WIRING OR LINES ARE PINCHED BETWEEN THE BRACKET AND FRAME.

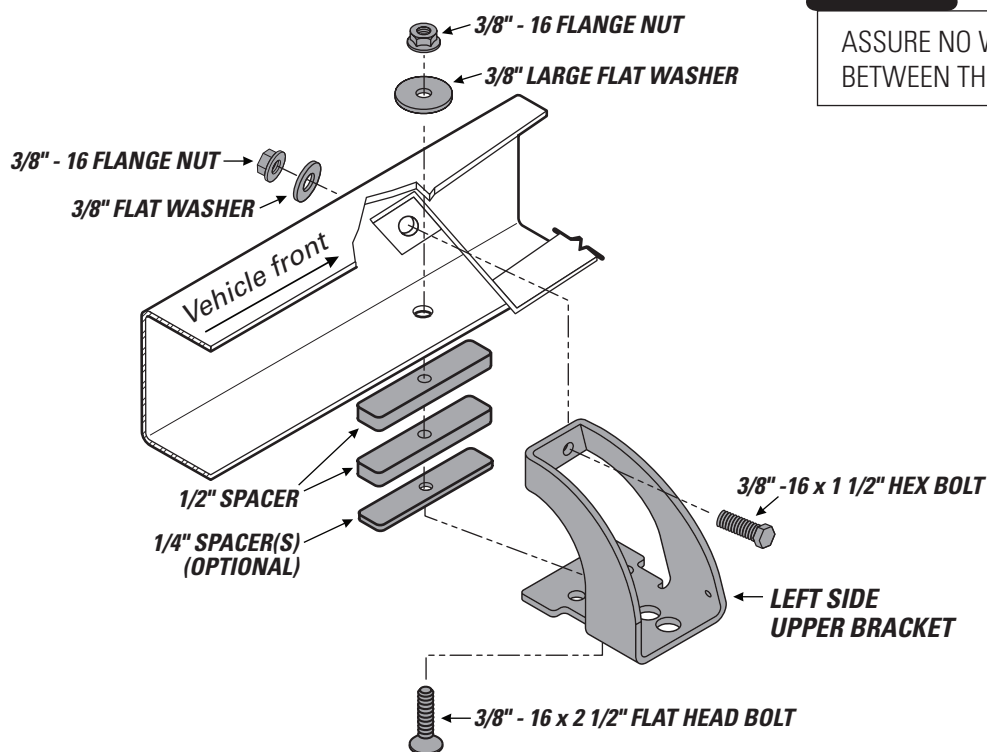

# 3

## FASTEN AIR SPRING TO UPPER BRACKET

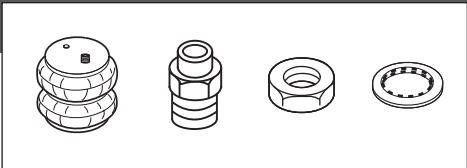

INSTALLING THE RIGHT SIDE? REMEMBER TO INSTALL THE HEAT SHIELD IN STEP 7 FIRST!

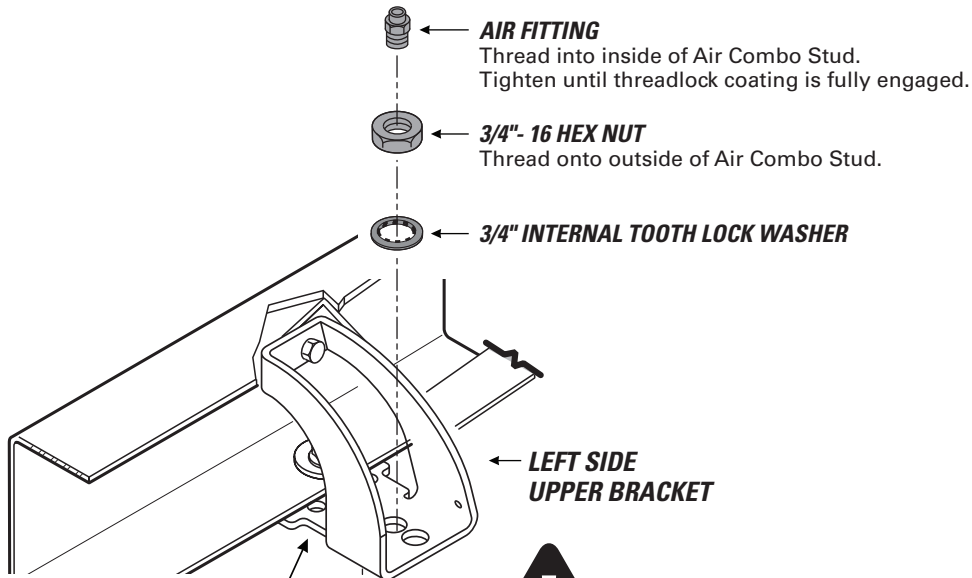

### VIEW FROM BELOW

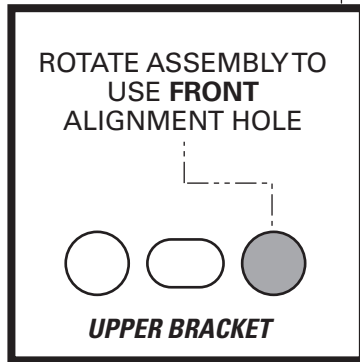

ALIGNMENT PIN ON AIR SPRINGS MUST BE INSTALLED TO FULLY SEAT INTO THE FRONT ALIGNMENT HOLE IN THE UPPER BRACKET. FAILURE TO DO SO WILL CAUSE IT TO BE PUSHED INTO THE BEAD PLATE, CREATING AN AIR LEAK, AND RESULTING IN AN AIR SPRING FAILURE THAT IS **NOT WARRANTABLE. THE ALIGNMENT PIN CANNOT HOLD 2,500 LBS! IT IS USED FOR ALIGNMENT ONLY!**

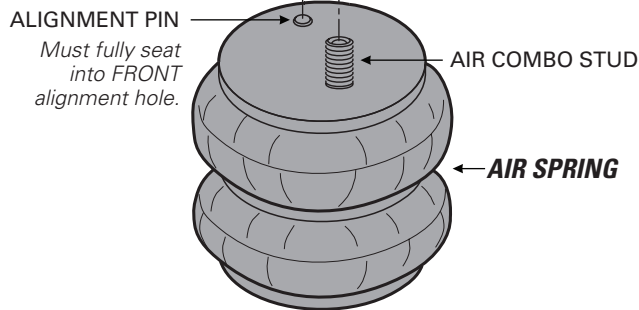

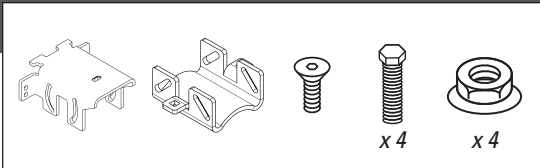

**1** Follow steps below to dry fit assembly. Make alignment marks as shown.

**2** Place bottom of Lower Bracket on the axle of the vehicle.

**3** Place the Upper Bracket above the Lower Bracket as shown. Assure both are tight against the leaf spring stack.

**4** Match the alignment marks and secure the Air Spring to the Upper Bracket, as shown.

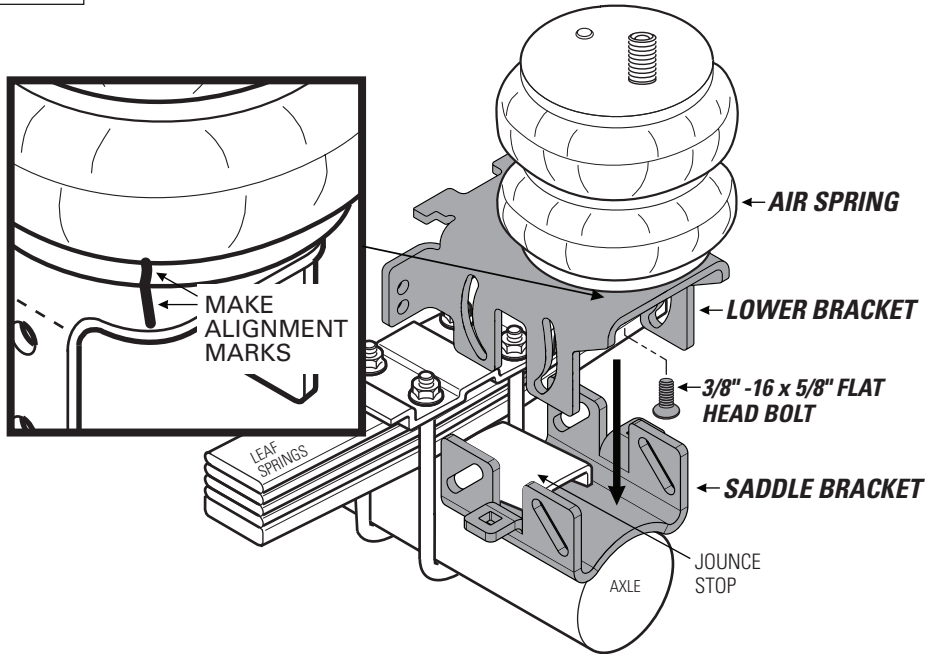

**5** Position the Lower Bracket as low as possible, while still clearing the jounce stop on the vehicle.

**6** Make sure the Lower Bracket is parallel to the ground.

**7** Use supplied fasteners in the bracket bolting slots.

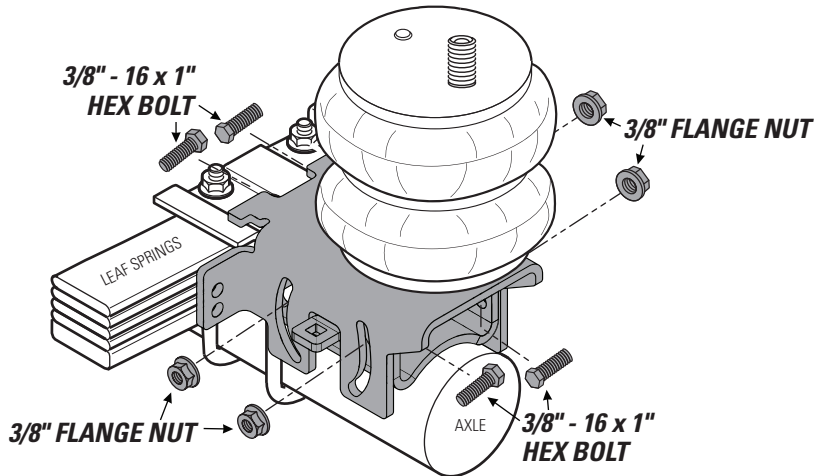

**! IMPORTANT: INSTALL ON THE LOWEST SETTING POSSIBLE FOR YOUR VEHICLE**

FAILURE TO DO SO CAN RESULT IN DAMAGED BRACKETS AND CAN VOID YOUR WARRANTY

**4-WHEEL DRIVE INCORRECT**

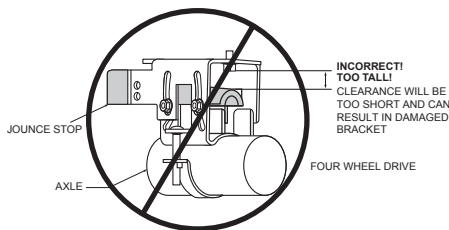

**4-WHEEL DRIVE CORRECT**

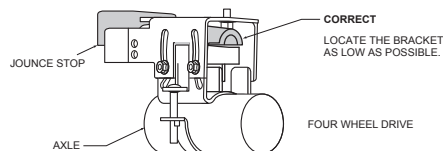

**2-WHEEL DRIVE CORRECT**

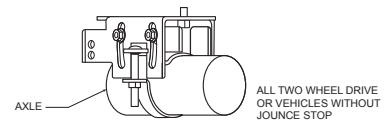

# 5

## SECURE LOWER BRACKET



USE YOUR HAND TO CHECK FOR THE PROPER CLEARANCE AROUND THE AIR SPRING. IF YOUR HAND DOES NOT FIT BETWEEN THE AIR SPRING AND OTHER COMPONENTS, IT WILL RUB!

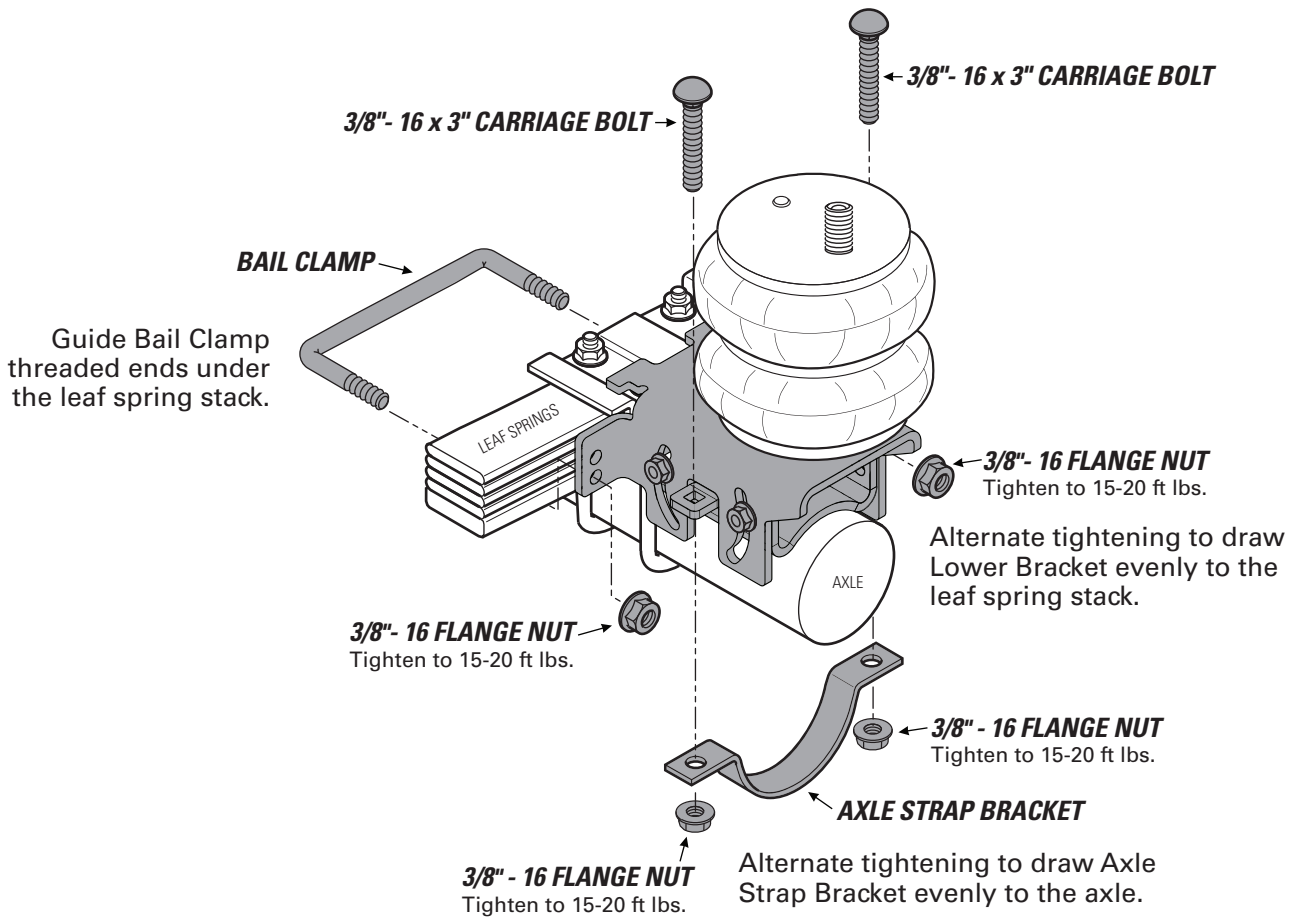
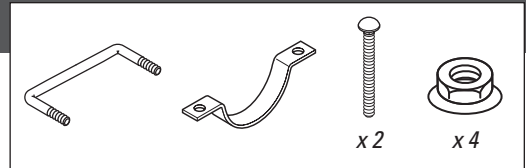

**AWESOME!** You're done with the left side. Move on to Step 6 to begin the right side installation.



INSTALL RIGHT SIDE UPPER BRACKET

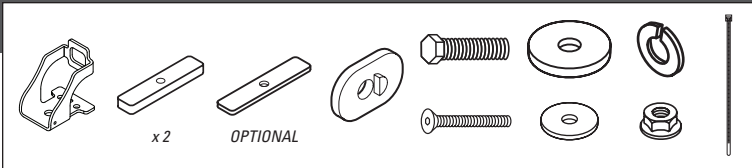

**1** Follow the steps below to install the right side Upper Bracket.

**2** Use supplied Nylon Tie to secure parking brake line to Upper Bracket as shown.

**3** Once completed, see Step 7 for Heat Shield Installation.

**4** Once Step 7 is complete for the right side, continue to Steps 3-5.



ASSURE NO WIRING OR LINES ARE PINCHED BETWEEN THE BRACKET AND FRAME.

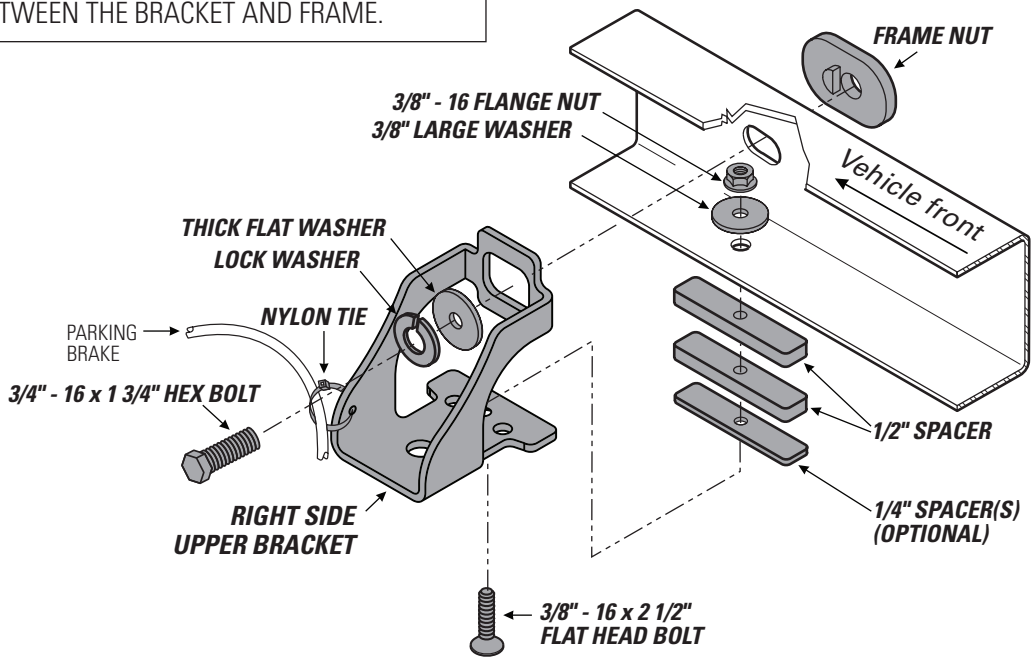

# 7

## INSTALL RIGHT SIDE WITH HEAT SHIELD

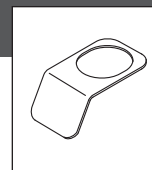

RIGHT SIDE INSTALLATION MUST INCLUDE HEAT SHIELD!

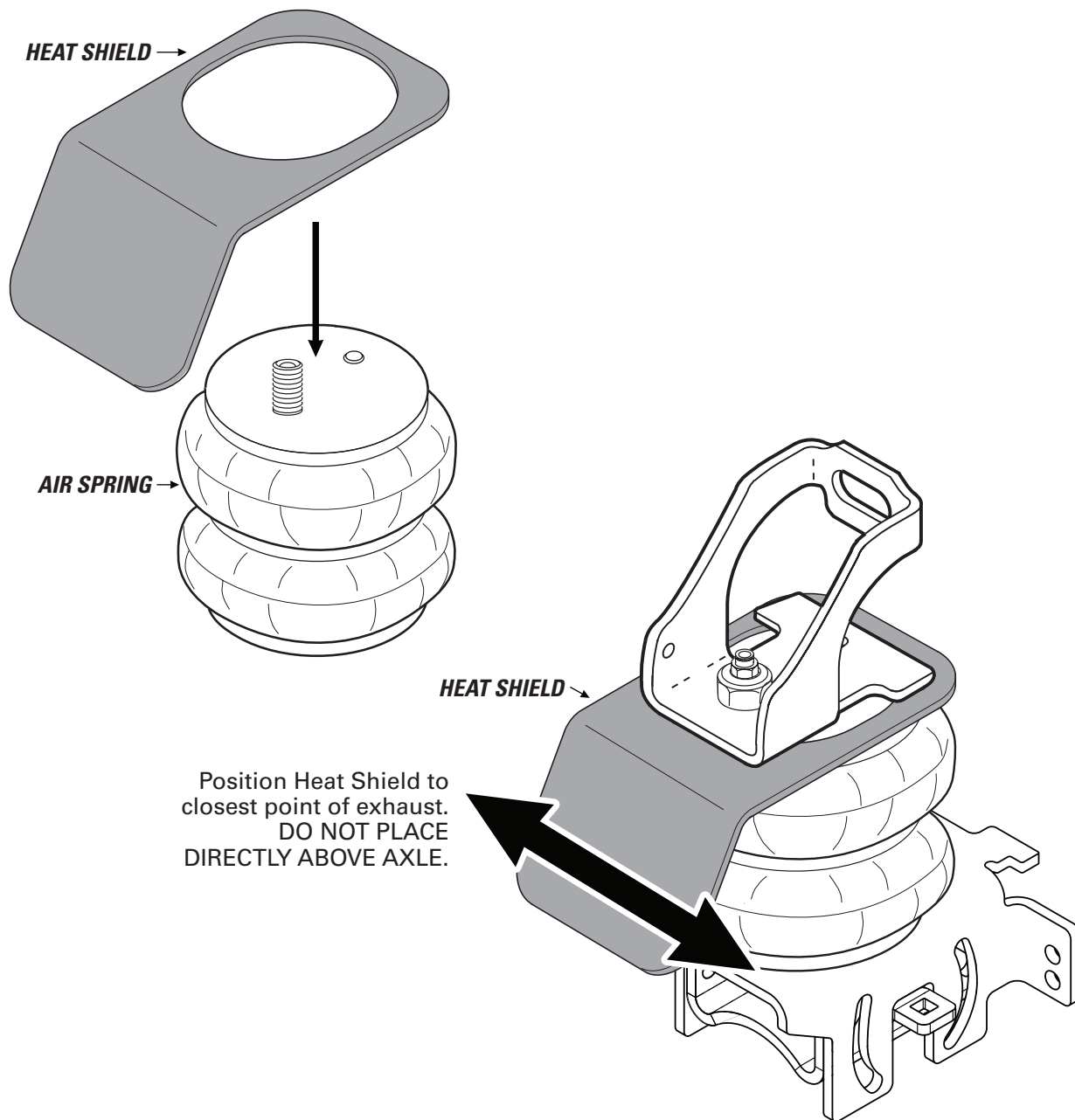

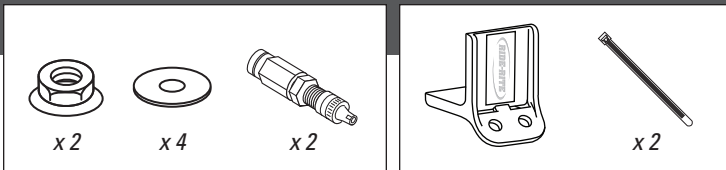

IF USING THE OPTIONAL NO-DRILL INFLATION VALVE BRACKET, CHOOSE OPTION 1. IF DRILLING, CHOOSE OPTION 2. **INFLATION VALVES MUST BE ACCESSIBLE BY AN AIR CHUCK.**

**1** Secure the Air Inflation Valve Bracket to a protected, secure location. **PROCEED TO STEP 3.**

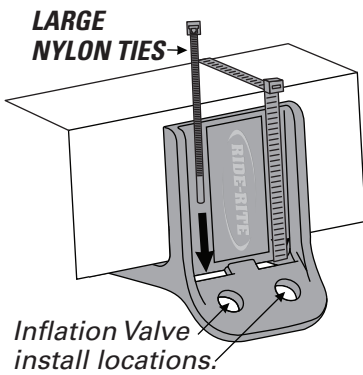

**2** Select a protected location to install the Inflation Valves, such as the bumper or the body of the vehicle.

Drill two 5/16" holes for Inflation Valve install locations.

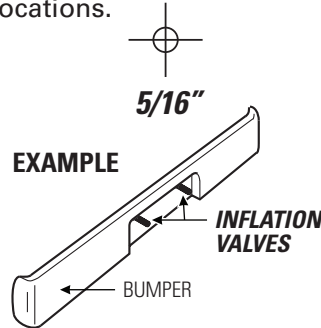

**3** Install Inflation Valve assembly as shown.

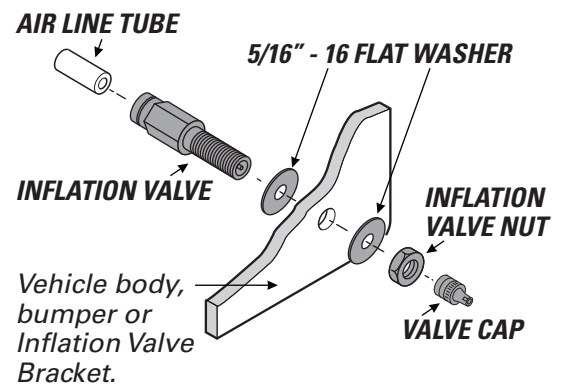

**1** Match Air Line Tube ends.



**2** Find center of Air Line Tube, make a square cut with tube cutter or sharp utility knife.

**DO**

Make sure the cut is as square as possible. Use a tube cutter or sharp utility knife.

**DON'T**

Fold or kink the Air Line Tube. Cut the Air Line Tube at an angle. Use pliers, scissors, snips, saws, or side cutters.

**PROPER AND IMPROPER CUTS IN THE AIR LINE TUBE**

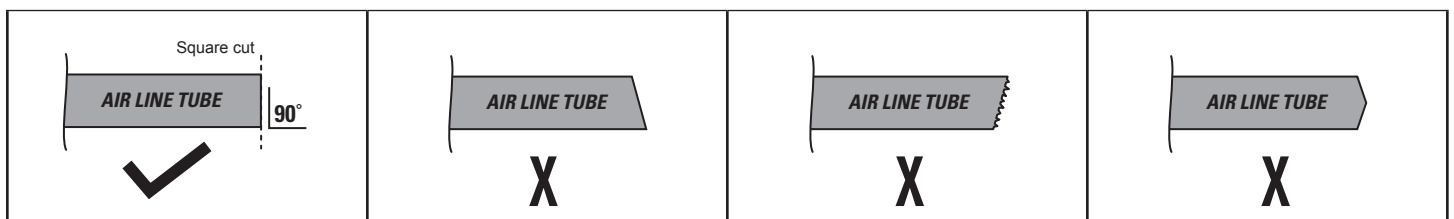

# 10

## INSTALLING AIR LINE TUBE INTO AIR FITTINGS AND INFLATION VALVE

**1** Insert end of Air Line Tube into Air Fitting.

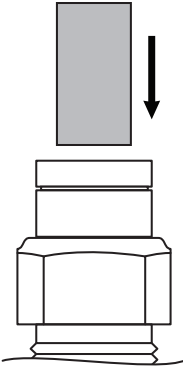

**2** Push Air Line Tube into Air Fitting as far as possible.

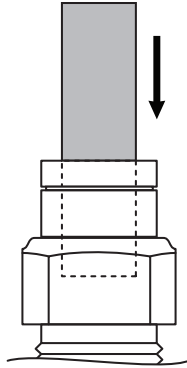

**3** Gently pull on the Air Line Tube to check for a secure fit.

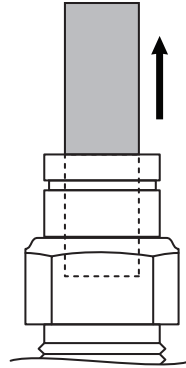

**4** To remove, push down collar and gently pull Air Line Tube away.

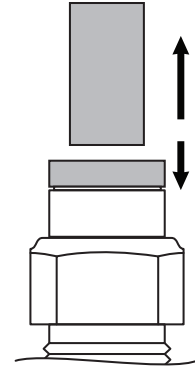

**Removal Tip:** Use a 1/4", 5/16", or 6mm open-ended wrench to push the collar down.

# 11

## ROUTE AND SECURE AIR LINE TUBES

Air Line Tube routes will vary, depending on your truck, and requires you to choose the best path from the Air Springs to the Inflation Valves. Use the instructions below to help you choose.

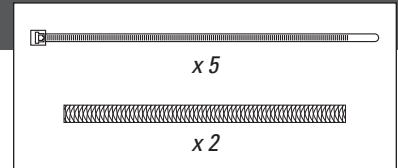

# DO

Select routes protected from heat, debris, and sharp edges. Use Thermal Shields near heat sources. Use Nylon Ties to secure the Air Line Tube.

# DON'T

Bend or sharply curve Air Line Tubes. Leave Air Line Tube exposed to sharp edges. Use unnecessary lengths of Air Line Tube. Route Air Line Tube near moving parts. Let Air Line tube hang unsecured from vehicle. Scar Air Line Tube while routing.

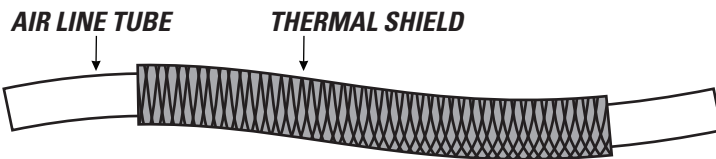

USE SUPPLIED THERMAL SHIELDS WHEN AIR LINE TUBE RUNS **WITHIN 6 INCHES** OF HEAT SOURCES.

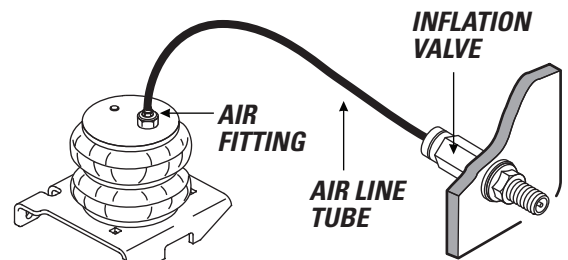

- 1** Place an air chuck onto the Inflation Valve and fill the system to **70 PSI**.

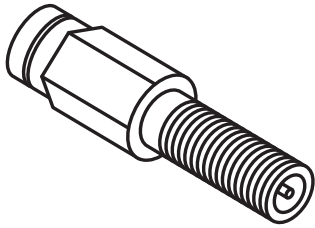

AIR SPRINGS INFLATE QUICKLY. CHECK AIR PRESSURE WHILE INFLATING.

- 2** Spray fittings with soap and water mixture.



- 3** Observe bubbles.

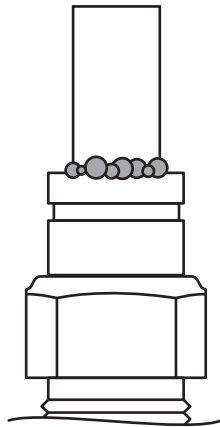

**SMALL SOAP BUBBLES  
THAT DO NOT EXPAND**

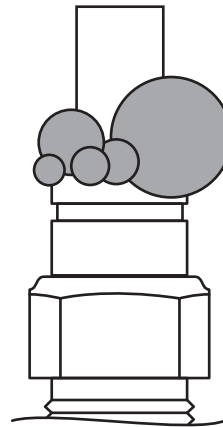

**SOAP BUBBLES  
THAT EXPAND**



# NO LEAKS?

Congratulations! Continue to Step 14 to finish installation. Review the Operating Instructions.

# LEAK?

Bummer. Continue to Step 13 to fix the leak.

- 1** Press the air valve on end of Inflation Valve to release all air pressure.

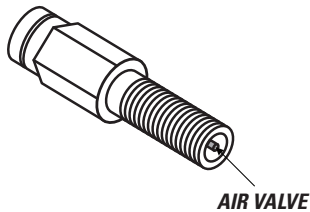

EXHAUST ALL AIR FROM THE SYSTEM PRIOR TO RELEASING AIR LINE TUBES FROM AIR FITTINGS.

#### LEAK AT AIR LINE TUBE AND AIR FITTING

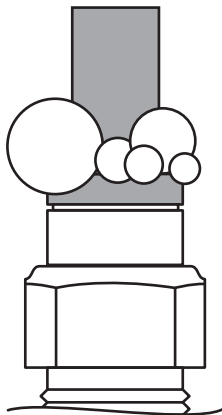

Release Air Line Tube (see page 11). Review proper cuts and procedures in Step 9. Repeat Steps 10 and 12.

#### LEAK AT BASE OF AIR FITTING ON AIR SPRING

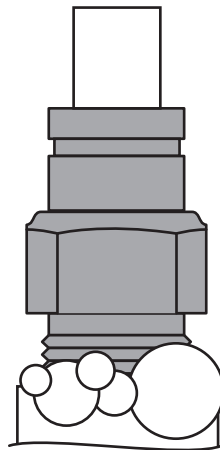

Tighten Air Fitting one turn or until leak stops.

#### LEAK OUT OF THE VALVE CORE ON INFLATION VALVE

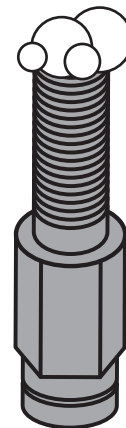

Tighten valve core with valve core wrench on Inflation Valve Cap.

# STILL HAVE A LEAK?

Refer to the Troubleshooting section of the Instruction Manual. If the leak persists, or if there is an issue with a leaking part, call 1-800-888-0650; Option 1; Option 1 for Tech Support.

**SAFELY RETURN VEHICLE TO OPERATIVE STATE**

If you removed any wheels during installation, install the wheels and torque the lug nuts to the manufacturer's specifications.

Safely remove any jack stands and wheel chocks used during installation.

Re-attach the negative battery cable.

**DOUBLE-CHECK AIR SPRING CLEARANCE**

Check the Air Springs once again for the proper 1/2" minimum clearance. Perform clearance check again when vehicle is under load.

**VEHICLE GVWR**

NEVER exceed the maximum load recommended by the vehicle manufacturer (GVWR). The GVWR can be found in your vehicle's owner's manual or on the data plate on the driver's side door. Consult your local dealership for additional GVWR specifications.

**READ AND UNDERSTAND THE OPERATING INSTRUCTIONS**

The Ride-Rite system can improve handling and comfort. Take the time to learn how to properly use and maintain your investment by reading the Operating Instructions.



USE YOUR HAND TO CHECK FOR THE PROPER CLEARANCE AROUND THE AIR SPRING. IF YOUR HAND DOES NOT FIT BETWEEN THE AIR SPRING AND OTHER COMPONENTS, IT WILL RUB!

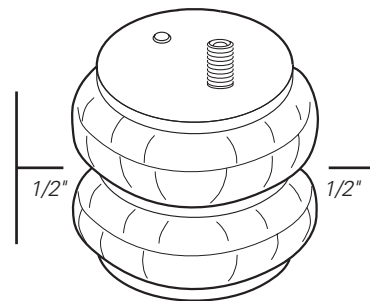

# ! IMPORTANT

**A MINIMUM OF 5 PSI MUST BE MAINTAINED IN THE AIR SPRINGS AT ALL TIMES**

Too much air pressure in the Air Springs will result in a firmer ride, while too little air pressure will allow the Air Springs to bottom out over rough conditions, and will not provide the improvement in handling that is possible.



MINIMUM PRESSURE



MAXIMUM PRESSURE (LOADED)



[riderite.com](http://riderite.com)

## BEFORE YOU DRIVE, CONFIRM THE FOLLOWING:

- Do you have a minimum of 5PSI in your Air Springs?
- Are your Air Springs standing 5 1/2" - 7" tall?
- Are your Air Springs properly aligned, left-to-right and front-to-back?
- Are your nuts and bolts tight?
- Put your paper work back into the sleeve and keep it in your glove compartment for future reference.
- You've been bagged...and now your suspension is Airide™ equipped! Show it off with the supplied decal!

5 1/2" - 7"

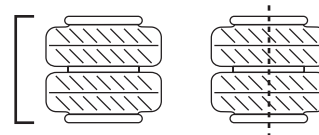

## NEED INSTALLATION HELP? 1-800-888-0650

Select Option 1 for Ride-Rite; Select Option 1 for Technical Support.

Or, email us at [rrtech@fsip.com](mailto:rrtech@fsip.com). If emailing, please include photos to help us better diagnose and understand any problems you may be experiencing.



CONNECT WITH US



@rideriteair



@rideriteair



Firestone RideRite



Firestone Ride-Rite