

BD Torq/Un-Loc Torque Converter Control System

Part# 1030398

ENSURE YOU READ ALL INSTRUCTIONS BEFORE INSTALLING THIS PRODUCT

TABLE OF CONTENTS

Welcome 3

The BD Torq/UnLoc Advantage 3

Operating The BD Torq/UnLoc..... 3

Transmission Quirks..... 5

Compatibility With Other Exhaust Brakes 5

Adjusting For Application..... 6

Wiring – With Exhaust Brake Installed 7

Testing with an Exhaust Brake 10

Wiring –Without Exhaust Brake..... 11

1996-2002 Dodge "TRANS" Relay Bypass..... 12

Wiring Diagrams..... 13

 Torq/UnLoc (Dodge Trucks) 13

 Brake Connection Diagrams..... 14

 BD Brake (12V Dodge & Chevy 6.5L) / PacBrake (Dodge) 14

 BD Brake (1998-2002 24V Dodge) 14

 Jacob’s E-Brake (6BTA)..... 15

The Torq/Unloc Basics 15

Questions? 16

Welcome

Thank you for purchasing the BD **Torq/UnLoc** Kit. This manual is to assist you with your installation and operation of the unit. We strongly suggest that you retain this manual for any future reference.

NOTE: For trucks with a Jacobs E-Brake system for the Dodge ISB 24 valve application and all US Gear D-Celerators, the brake cannot be hooked up to the module. Follow the instructions that are for “Without Exhaust Brake”.

The BD Torq/UnLoc Advantage

Currently, exhaust brake usage can cause high temperatures in the automatic transmission due to torque converter slippage, and, only 10% to 80% of the retarding force is transferred through the fluid coupling of most torque converters.

The **BD Torq/UnLoc** commands the lock-up clutch of the torque converter to stay engaged when the **BD Exhaust Brake** is activated. This allows for up to 100% of the retarding force to be transferred in 3rd and 4th gear and the transmission oil temperature to remain low because of little to no slippage occurring when the converter is in these selected gears.

The **BD Torq/UnLoc** is also able to prevent the ECM from activating the lock-up clutch when such an action would drag the engine rpm out of the optimum torque range, or, when traveling at such speeds that would cause the ECM to cycle the lock-up clutch in and out.

Operating The BD Torq/UnLoc

The **Torq/UnLoc** works off of a lighted 3-position toggle switch that will only take effect when the vehicle is above a set speed (approximately 25mph to 30mph) and the torque converter lock-up clutch is engaged. The lock-up clutch usually engages when the vehicle is cruising with little throttle action. (The manual unlocking of the clutch can be activated at any time.)

On most vehicles, the lock-up clutch can be manually engaged by applying pressure to the accelerator pedal until lock-up engages, then lifting the foot off of the accelerator. Accelerator pedal pressure is also required after shifting out of or into overdrive to re-engage the lock-up. The **Torq/UnLoc** is programmed to disengage the lock-up clutch once the vehicle's speed drops below a set speed.

BD Engine Brake, Inc.

Plant Address: Unit A10, 33733 King Rd, Abbotsford, BC, Canada V2S 7M9

U.S. Shipping Address: 88-446 Harrison St, Sumas, WA 98295 U.S. Mailing Address: P.O. Box 231, Sumas, WA 98295

Phone: 604-853-6096 Fax: 604-853-8749 Internet: www.bd-power.com

When the 3-Position toggle switch is in the **Up (Red Light)** position, it will manually keep the converter lock-up clutch engaged. This is referred to the **TorqLoc** mode.

The **Middle (White Light)** position is the off/neutral position and if a compatible exhaust brake is hooked up to the system, the module will keep the lock-up engaged when the exhaust brake valve is activated (brake switch turned on and accelerator pedal at idle position). This is referred to the **Stock/AutoLoc** mode.

In the **Down (Green Light)** position, the converter lock-up clutch will be prevented from locking up. This is referred to the **UnLoc** mode.

For proper operation of the **Dodge** transmission, the lock-up clutch must be disengaged before the transmission will shift out of overdrive and into 3rd gear.

The **Torq/UnLoc** module compensates for this by disengaging the lock-up clutch when the **O/D OFF** (Overdrive Off) button is activated to turn the overdrive off while in the **TorqLoc** or **Stock/AutoLoc** modes. To reactivate the lock-up, apply pressure to the accelerator pedal until lock-up engages, then lift your foot off of the accelerator pedal.

In addition, with Dodge trucks, to prevent excess slippage with the lock-up clutch, the turbo boost pressure should be equal to or less than 1psi for every 100 engine rpm (example: 18psi or less at 1800rpm) when the engine rpm is below 1800rpm.

The transmission should be shifted out of overdrive if speed drops below 40 mph. If not, there could be transmission shudder as the vehicle's speed decreases until it reaches the set speed that the **Torq/UnLoc** unit will disengage lock-up.

With Dodge trucks, the module has an Overdrive inverter option that will disengage the overdrive when the truck starts to move after being started up.

This will prevent possible transmission shudder on trucks with raised horsepower and will allow for the transmission to lock-up the converter clutch in third gear before reaching overdrive when starting to up-shift from a dead stop, allowing cooler fluid temperatures when driving at "city" speeds.

This is an option and does not need to be connected for proper operation of the **Torq/UnLoc** module. (Ignore all references to the "Inverter" if this option is **not** desired)

Transmission Quirks

Some Dodge trucks built between the production dates of 09/95 to 04/96 have had ECM programming for transmission control that has caused some lock-up control problems and/or will cause the **Torq/UnLoc** not to operate correctly. If this occurs, the computer can be "re-flashed" to current specs at most Dodge dealerships. Labor charges of approximately 30 minutes may apply.

Some Dodge trucks that are 1999-2002 model years and are of California specifications may require the transmission relay to be re-installed back into its socket. This relay would have been removed in the "1996-2002 Dodge 'TRANS' Relay Bypass" section of this manual.

Other items installed that may affect the operation of the transmission may have an effect on the operation of the **Torq/UnLoc** (i.e. auxiliary transmissions). Please make this known when contacting the BD Technical Service Department.

Compatibility With Other Exhaust Brakes

Most of the provided diagrams, instructions, and parts relate to the installation and operation of this unit in conjunction with any BD Exhaust Brake.

In this manual, we have provided some diagrams and additional instructions for other systems that we have had access to their diagrams. An installation in conjunction with any other system should only be done with instruction from one of our BD Technicians, with wiring diagrams and/or schematics provided to them. Additional lead-time, parts and/or labor may be required.

For Jacobs E-Brakes installed on Dodge trucks with the 24 valve ISB engines and all US Gear D-Celerator applications, ignore hooking up the **Torq/UnLoc** to the brake wiring and follow the wiring instructions as if there was no exhaust brake installed.

NOTE for PacBrake exhaust brakes only: If the truck has a 24 Valve engine or is a 6BTA engine with 60 lb springs, remove the PacBrake valve and drill out the pressure relief hole from 9/23" to 31/64". This step is NOT required for the 24 valve engines or newer models.

Adjusting For Application

Before installing, open the box up by removing two screws on bottom of module. On the opposite end of the circuit board from the terminals, there is selection of 8 dipswitches.

These dipswitches control the speed that the **Torq/UnLoc** module will disconnect the lock-up clutch. We have provided settings for the module to disconnect the lock-up at approximately 25mph to 30mph. If you find that the set speed is too high or low for the vehicle, phone our technical service department for alternative settings.

NOTE: To ensure proper function of the dip-switches, flip each dip-switch back and forth once before setting them, even if the dip-switches are already set for the application that it's being installed on.

The "**LED**" (Light Emitting Diode) on the circuit board will show a Red light when the vehicle has surpassed the set speed and the toggle switch is in the Up/Red-light position, or, when the exhaust brake is activated and the toggle switch is in the Middle/White-light position. Once the unit is installed, test drive the vehicle to make sure the light comes on at the set speed.

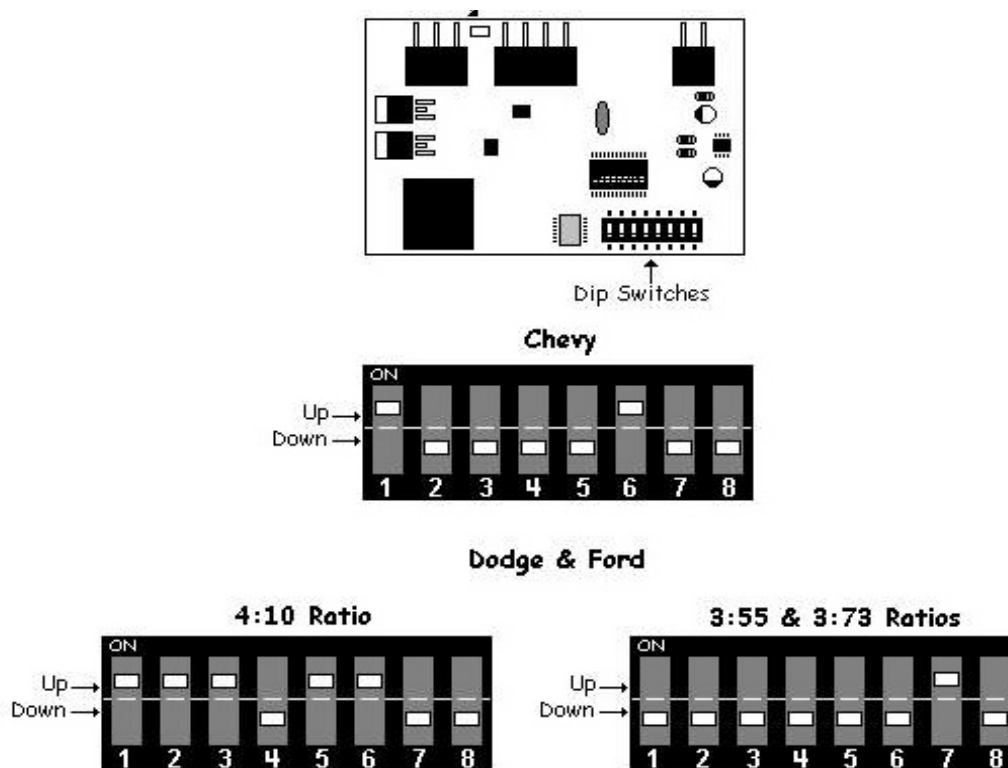

BD Engine Brake, Inc.

Plant Address: Unit A10, 33733 King Rd, Abbotsford, BC, Canada V2S 7M9

U.S. Shipping Address: 88-446 Harrison St, Sumas, WA 98295 U.S. Mailing Address: P.O. Box 231, Sumas, WA 98295

Phone: 604-853-6096 Fax: 604-853-8749 Internet: www.bd-power.com

Wiring – With Exhaust Brake Installed

Disconnect the ground (negative) terminals on all vehicle batteries before starting installation. The following instructions will be divided up for wiring up each individual terminal labeled on the **Torq/UnLoc** module. These terminals in these instructions will be numbered starting from the top at the +12V terminal. Follow along with the diagrams after the written instructions for ease of installation.

NOTE: When wiring the **Torq/UnLoc** module, consider leaving enough slack on the wires so that the module can be placed to one side during test-driving before finally securing unit under dash. Reconnect Ground terminals on batteries after installation.

+12V	#1	Torq/UnLoc power lead (Red wire)
Using a test light or multi-meter, find a key switched +12 Volt power source in the wiring harness under the dash. Connect the Red wire to it using a black Posi-Tap™ and connect the other end of the Red wire to the +12v terminal on the module.		

GND	#2	TorqLoc ground (Black wire)
Connect to any bolt/screw under the dash that is a good ground.		

VSS	#3	Vehicle Speed Sensor (Green wire)
Locate the VSS (Vehicle Speed Sensor) wire in the vehicles computer wiring harness (see chart). Run the Torq/UnLoc Green wire to the VSS wire and cut off any excess, leaving some slack. Connect to the VSS wire using a gray Posi-Tap™, or, solder the Green wire to the VSS wire and protect it from the elements (i.e. liquid electrical tape).		
DODGE (5.9L)	2004-2005	Pin 11 at ECM C2 50 pin (Dark Green w/Yellow tracer)
	1996-2003	Pin 27 at PCM (White w/Orange Tracer)
	1994-1995	Pin 47 on PCM (White w/Orange Tracer)
CHEVY (6.5L)	1994-2000	Pin 15 (Dark Green w/White Tracer) at VSS Buffer beside the ECM (Behind glove box)
	1992-1993	Light Blue w/Black Tracer at VSS Buffer by ECM

BPS	#4	Brake Power Signal (Brown Wire)
<p>The module is looking for the 12-volt positive signal that triggers the exhaust brake to activate.</p> <p>Connect the Brown “Y” wire to BPS terminal on the module and connect the Brown wire from the toggle switch to one of the open ends of the “Y” wire. Connect one end of the supplied section of Brown wire to the other open end of the “Y” wire.</p>		
Brake System		Connection
BD Brake & Pac Brake (Dodge Application)		Posi-Tap™ onto the wire leading from the throttle switch/DFIV going to the exhaust brake.
Jacobs E-Brake (Dodge 6BTA)		Posi-Tap™ onto the black wire on the wire harness at the throttle switch.

O/D SW	#5	Dodge Overdrive Switch (White wire)
<p>For 1994-98 Dodges, locate the Light Green w/Orange Tracer wire, or, the Orange w/White on 1999-2002 Dodges, in the harness above the master brake cylinder (NOTE: The same harness that the VSS wire is usually found). For 2004 Dodges, locate the Dark Green wire at the ECM on the driver side of the engine. Pin 13 on the ECM C2 connector (50 pin).</p> <p>Cut the Torq/UnLoc White wire to length, while leaving some slack, and attach a gray Posi-Tap or solder the wire to the O/D wire and protect them from the elements (ie. Liquid electrical tape).</p>		

PCM & TCC	#6-7	Converter Control (Yellow #6 and Blue #7 wire)		
<p>Locate the vehicle's Torque Converter Control (TCC) as described in the following chart. Cut the applicable wire and attach one side of a blue Posi-Lock connector to the wire leading back to the transmission, and, attach one side of another blue Posi-Lock connector to the wire heading to the vehicles computer (ECM or PCM).</p> <p>Connect the Torq/Unloc yellow wire to the PCM (#6) terminal on the module. Connect the 2-foot long blue wire of the supplied relay to the TCC (#7) terminal and connect the supplied long blue wire to the other blue wire on the relay.</p> <p>Connect the purple wire of the relay to the purple wire on the toggle switch. Run the free yellow and blue wires to the cut Converter Control wire and cut off any excess, leaving some slack. Attach a blue Posi-Lock connector to the yellow wire and connect it to the wire heading to the vehicle's computer. Attach another blue Posi-Lock connector to the blue wire and connect it to the wire heading back to the transmission.</p> <p>Instead of using the blue Posi-Lock connectors, you could also solder the wires. After the wiring is complete, mount the toggle switch in a convenient location.</p> <p>NOTE: Some vehicles have more than one wiring harness on the transmission.</p>				
Make/Model	Year	Wire Color	Pin #	Location
DODGE (5.9L)	2004-2005	Y/LB	25	ECM C2 50 Pin Connection
	1996-2003	OR/BK	11	PCM C2
	1994-1995	OR/BK	54	PCM
CHEVY (6.5L)	1994-2000	Unplug harness from transmission then look inside plug and identify which wire is going to the "S" pin (usually Brown)		
	1992-1993	TAN/BK	"J" on Transmission	
INVERTER	#8	Optional Overdrive Disable (Orange Wire)		
<p>For 1994-98 Dodges only. Connect the Orange wire to the Inverter terminal and run it to the same harness where the O/D Switch and VSS wire were found, cutting of excess and leaving some slack. Locate the Orange w/White Tracer and using a gray Posi-Tap™ connector or soldering, connect Orange wire to O/D wire. 1999+ Dodges do not require the connection of the wire for this option.</p>				

BD Engine Brake, Inc.

Plant Address: Unit A10, 33733 King Rd, Abbotsford, BC, Canada V2S 7M9

U.S. Shipping Address: 88-446 Harrison St, Sumas, WA 98295 U.S. Mailing Address: P.O. Box 231, Sumas, WA 98295

Phone: 604-853-6096 Fax: 604-853-8749 Internet: www.bd-power.com

For 1999-2002 Dodges, if the overdrive inverter option is desired, flip Dip Switch #8 to the “UP” position, no matter what gear ratio you set the other switches to.

**BRAKE****#9****N/A**

This connection is not used in the *Torq/UnLoc* kit.

Testing with an Exhaust Brake

With the module pulled out enough to be easily visible while driving, take the vehicle for a drive. Turn the toggle switch to the **Up (Red Light)** position and first check that the LED light comes on once the vehicle has surpassed the set speed. If the LED fails to illuminate after the set speed, check the dip-switch settings, the VSS wire color and the connection to that wire. Also check that the wire is on the correct terminal at the module, and make sure there is a good power source and ground for the module.

With no traffic around, turn on the exhaust brake and turn the toggle switch to the **Middle (White Light)** position, then cruise at a constant speed above the set speed on the module, then let off the throttle. The brake should have activated and you should feel the hold back.

Turn the brake off to make sure the brake and lock-up clutch disengages. Turn the brake on and cruise again at a constant speed, then let off the throttle and let the vehicle slow down below the set speed, making sure the lock-up releases below the set speed. If these situations fail to occur, then check the wiring to the brake and module, and check terminal locations on the module.

While cruising at a constant speed and allowing the vehicle's ECM to lock-up the clutch, turn the toggle switch to the **Down (Green Light)** position, which should disengage the clutch. If this does not occur, check the connections at the purple wires (**#6-7**) and make sure that there is a 12V signal on the line.

On Dodge trucks, after starting up the truck and starting to drive the O/D off light should have illuminated (if that option was hooked up). With the brake turned on, the switch in the **Middle (White Light)** position and the O/D off light is no longer illuminated, drive until overdrive is reached then let off the throttle. With the brake and lock-up clutch engaged, push the overdrive button to check that the lock-up clutch disengages and the transmission shifts out of overdrive.

BD Engine Brake, Inc.

Plant Address: Unit A10, 33733 King Rd, Abbotsford, BC, Canada V2S 7M9

U.S. Shipping Address: 88-446 Harrison St, Sumas, WA 98295 U.S. Mailing Address: P.O. Box 231, Sumas, WA 98295

Phone: 604-853-6096 Fax: 604-853-8749 Internet: www.bd-power.com

If this fails to occur, check the O/D wire color and connection to that wire and that the wire is on the right terminal at the module.

If any of the functions still fail to occur, phone our technical service department for further assistance. To bypass the effects the module (if required), unplug the **blue** and **yellow** wires of the transmission wire and plug the transmission wires back together. After final wiring and testing has been done on the vehicle, secure the module to a harness or a bracket under dash with tie wraps.

Wiring –Without Exhaust Brake

This includes Jacobs E-Brake for Dodge ISB and US Gear D-Celerator exhaust brakes.

For those applications where there is no exhaust brake installed or where the automatic feature of the **Torq/UnLoc** module is not desired or cannot be installed, follow the same wiring instructions as in the previous pages, except ignore the connecting of the section of **brown** wire to the “Y” wire and brake wire (#4). Also, ignore the chart of where to hook up that section of **Brown** wire (on next page).

NOTE: The **Mid (White Light)** position on the toggle switch now serves only as a stock ECM operation.

1996-2002 Dodge "TRANS" Relay Bypass

Remove the cover on the Power Distribution Center (PDC) box, behind the driver's side battery. Replace the "TRANS" relay (see diagrams below, or bottom of PDC cover) with the copper jumper provided.

This IS NOT required on 1999-2002 California Spec. model trucks.

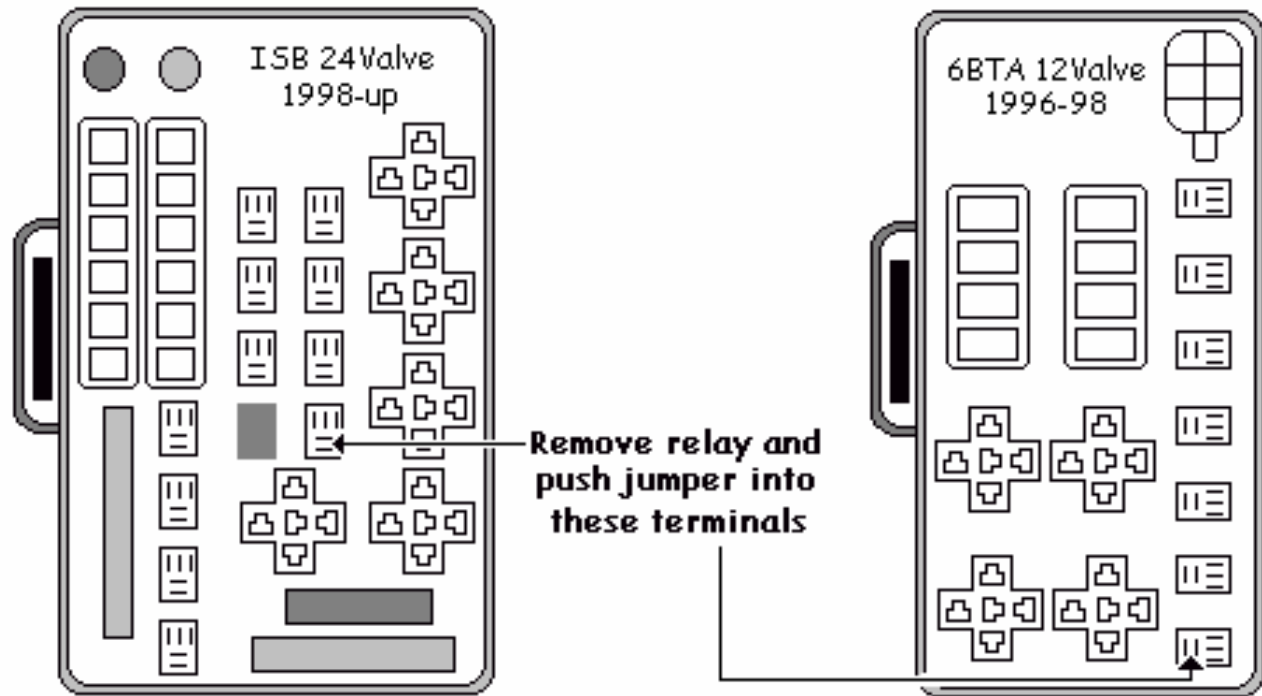

If the Engine Service Light comes on after operation, try reinstalling the relay then clear the fault code from ECM.

Wiring Diagrams

Torq/UnLoc (Dodge Trucks)

Omit this connection if the exhaust brake cannot be or is not being connect to the system

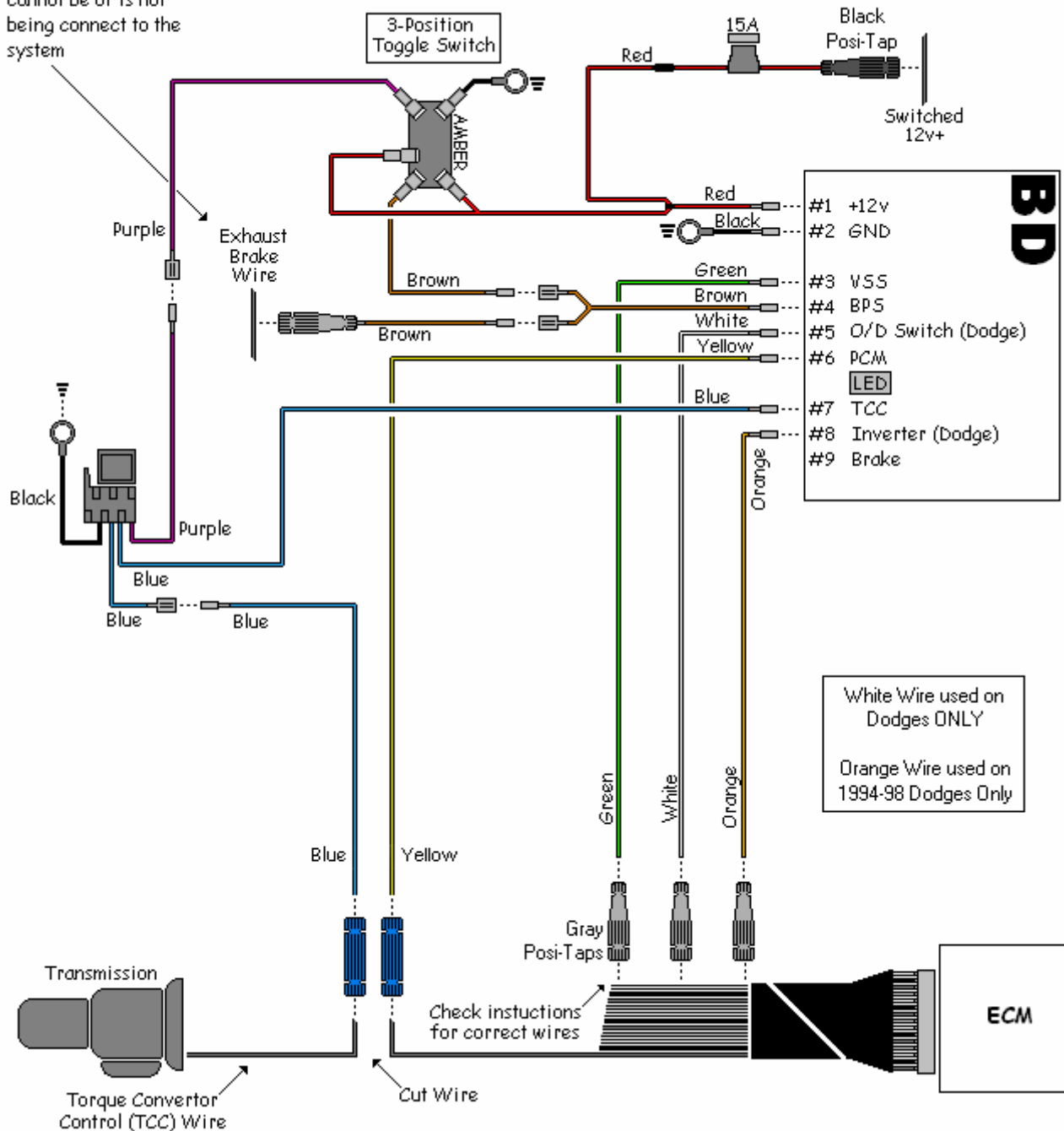

BD Engine Brake, Inc.

Plant Address: Unit A10, 33733 King Rd, Abbotsford, BC, Canada V2S 7M9

U.S. Shipping Address: 88-446 Harrison St, Sumas, WA 98295 U.S. Mailing Address: P.O. Box 231, Sumas, WA 98295

Phone: 604-853-6096 Fax: 604-853-8749 Internet: www.bd-power.com

Brake Connection Diagrams

BD Brake (12V Dodge & Chevy 6.5L) / PacBrake (Dodge)

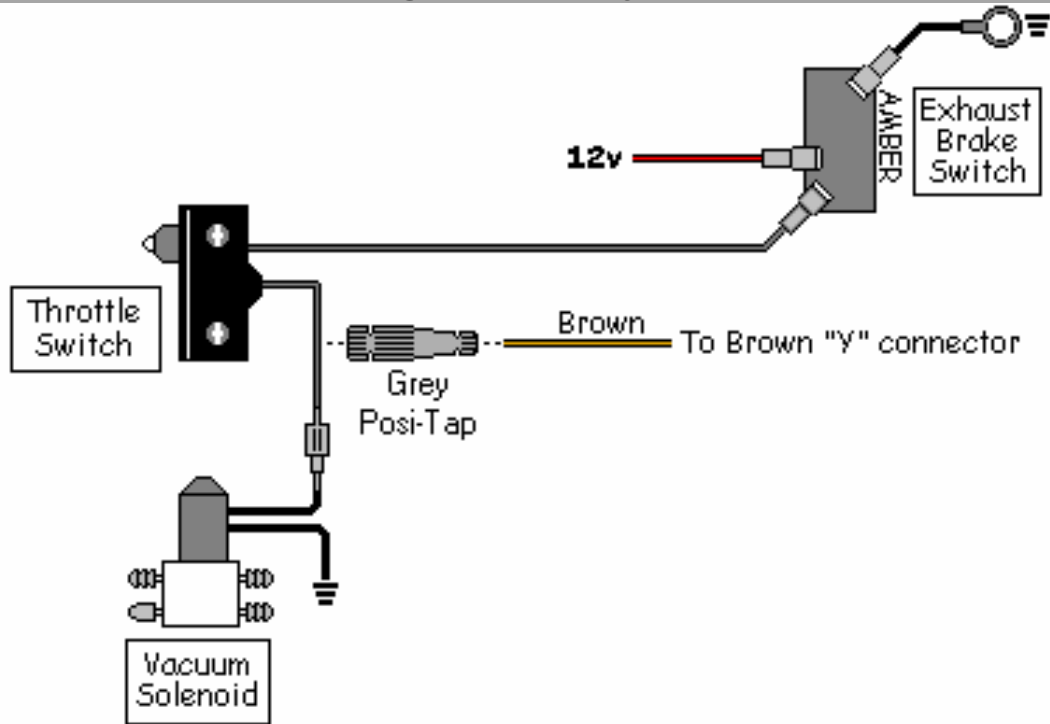

BD Brake (1998-2002 24V Dodge)

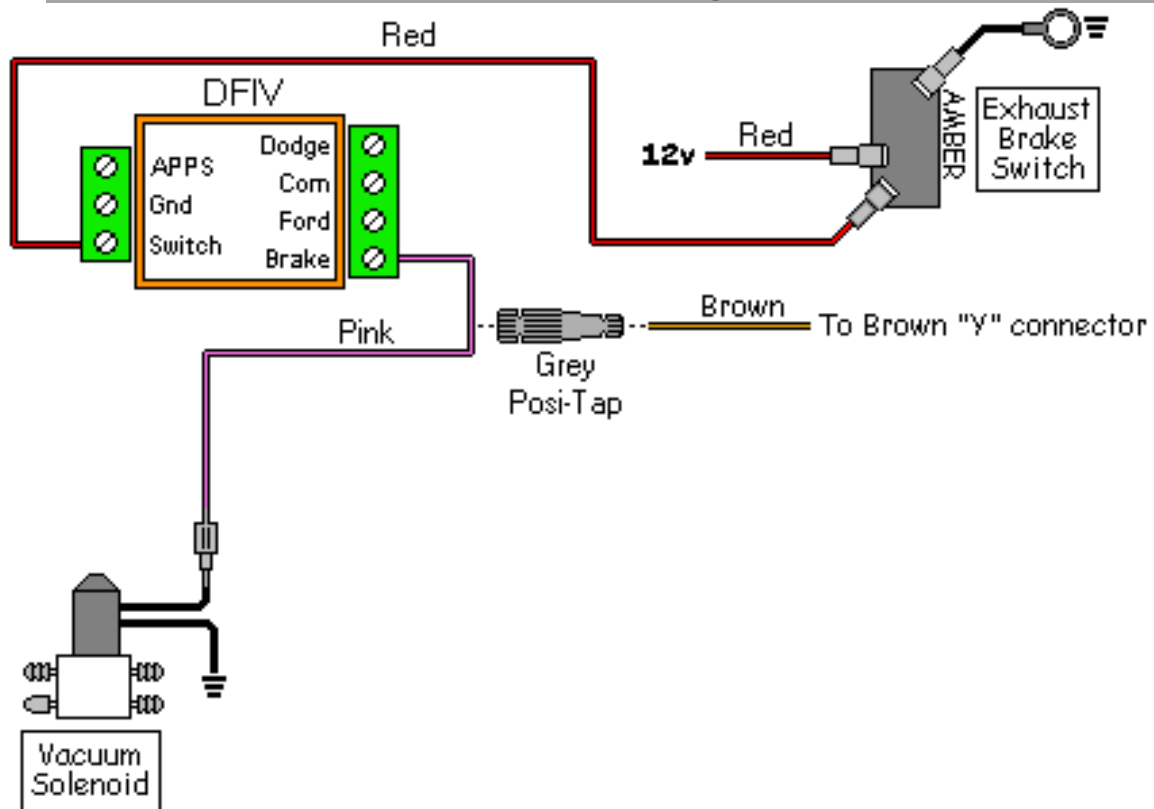

Jacob's E-Brake (6BTA)

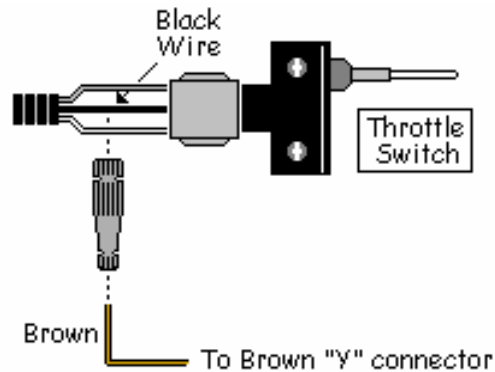

The Torq/Unloc Basics

The basic difference between the TorqLoc (Up/Red-light) and AutoLoc (Middle/White-light) functions is that the AutoLoc automatically controls the TCC lock up signal once it receives a power signal from the exhaust brake switch, and, the TorqLoc is for manual lock-up of the clutch. So in comparing between the AutoLoc and the TorqLoc, the TorqLoc will force the converter clutch to lock up and the AutoLoc will only hold a converter clutch that is already locked up.

With Dodge transmissions, when you ask for an overdrive to third gear downshift, the TorqLoc doesn't wait for the computer to lock up the clutch, it sends its own signal to the converter clutch, and as long as you are above the set speed and the transmission is hydraulically correct (throttle pressure is applied), the TorqLoc will force a lock up.

The AutoLoc cannot force a lock up, it can only hold it on deceleration, so once the downshift into third gear has occurred, lock-up must be reengaged with light throttle application. The Dodge transmission does not lock up in third gear from a dead start unless the overdrive is turned off, and it will not allow overdrive-to-third gear downshifts if the torque converter clutch is locked up. The Torq/Unloc module compensates for this via the overdrive switch and inverter functions.

With the AutoLoc, while driving with the overdrive turned off and the exhaust brake turned on, the transmission shifts from first to second to third and then locks up. Anytime after the lock up has occurred and you take your foot off the accelerator, the AutoLoc will hold the torque converter clutch locked until about 25mph, and then it will then turn off the torque converter clutch. When driving on the freeway in overdrive, with the torque converter clutch locked up and the exhaust brake turned on, if you release the throttle the AutoLoc will hold the torque converter clutch locked up. To increase the amount of retarding horsepower, down shift into third by turning off the overdrive.

BD Engine Brake, Inc.

Plant Address: Unit A10, 33733 King Rd, Abbotsford, BC, Canada V2S 7M9

U.S. Shipping Address: 88-446 Harrison St, Sumas, WA 98295 U.S. Mailing Address: P.O. Box 231, Sumas, WA 98295

Phone: 604-853-6096 Fax: 604-853-8749 Internet: www.bd-power.com

When downshifting with Dodge trucks, you have to apply throttle pressure until the factory computer says everything is okay and locks up the torque converter clutch. As soon as this happens, you should remove throttle pressure and the AutoLoc will keep the torque converter clutch applied until you get down to about the 25mph mark. The set speed is adjustable and one can set it for a higher mph so you don't have to worry about remembering to turn off the overdrive, or, lower the set speed if one has 4:10 gears or a 2nd Gear Lock-Up valve body.

There may be times when you may need to make a quick stop or slow down which canceling the AutoLoc or TorqLoc functions may be needed. Such conditions may be: do not require the extra retarding horsepower of third gear, do not have time to wait for the downshift and applying throttle to wait for lockup (this would all take about 4-6 seconds), and/or you do not want the shuddering that would occur when you have a locked up torque converter clutch and you are going to be doing less than 35 mph in overdrive.

You can do any of the following four actions to cancel out the system: 1) turn off the exhaust brake, 2) turn off the overdrive, 3) lightly step on the throttle pedal, or 4) pull the gearshift lever down into second gear. Turning off the overdrive or the exhaust brake is the preferred of the four options.

The TorqLoc function should only be used under light throttle applications. No matter whose torque converter you are using, the converter clutch has only so much holding power and exceeding this will start to slip the clutch, thereby starting the demise of your converter clutch. An example of when to use the TorqLoc position would be when you are on a winding road where you are on and off the throttle a great deal and you do not want to like the ECM locking and unlocking the converter clutch.

The TorqLoc will hold the converter clutch locked up, preventing that from happening. You must keep in mind while doing this that if you apply too much throttle pressure, especially at the lower rpm band, you may start to slip the converter clutch. A general rule of thumb when holding the converter clutch locked up is that no more than 1 lb of boost for every 100 rpm of engine speed (i.e. maximum 20lbs at 2000 rpm).

The UnLoc function works directly opposite to the TorqLoc function by manually preventing the clutch from locking-up. This function is useful when the ECM locking-up the clutch would drag the engine rpm out of the optimum torque range, or, when traveling at such speeds would cause the ECM to cycle the lock-up clutch in and out.

Questions?

Thank you for purchasing the BD Torq/UnLoc, please check our web site at www.bd-power.com for other performance products such as BD PressureLoc. For info on our Performance Transmissions and other components, please call, fax, or E-mail our BD Technical Service Department, 8:30am to 4:30pm Pacific Time, Monday to Friday.

BD Engine Brake, Inc.

Plant Address: Unit A10, 33733 King Rd, Abbotsford, BC, Canada V2S 7M9

U.S. Shipping Address: 88-446 Harrison St, Sumas, WA 98295 U.S. Mailing Address: P.O. Box 231, Sumas, WA 98295

Phone: 604-853-6096 Fax: 604-853-8749 Internet: www.bd-power.com

BD ENGINE BRAKE DISCLAIMER OF LIABILITY

Other than as expressly set forth herein, BD ENGINE BRAKE, Inc. (hereafter collectively, "SELLER"), together with its distributors, jobbers and dealers shall in no way be responsible for the PRODUCT'S proper use and service. In no event shall SELLER be liable for any special, incidental, indirect or consequential damages of any kind or nature, whether or not BUYER was advised of the possibility of damage, arising or resulting from the use or performance of the PRODUCT, and BUYER hereby waives any and all such claims.

BUYER acknowledges that he/she/it is not relying on SELLER'S skill or judgment to select or furnish goods suitable for any particular purpose and that SELLER has no liability that will extend beyond the scope of the limited warranty contained herein, and BUYER hereby waives all remedies or liabilities, expressed or implied, arising by operation of law or otherwise, (including, without limitation, any obligations of SELLER with respect to fitness for any particular purpose; merchantability; and special, incidental, indirect or consequential damages) or whether or not occasioned by SELLER'S negligence.

SELLER disclaims any warranty and expressly disclaims any liability for personal injury or damages related to BUYER'S use of the PRODUCT. BUYER acknowledges and agrees that the disclaimer of any liability for personal injury is a material term for this agreement and BUYER agrees to indemnify SELLER and hold SELLER harmless from any claim related to the PRODUCT and its use or performance. Under no circumstances will SELLER be liable for any damages, liabilities, costs or expenses incurred as a result of by reason of the use, performance or sale of the PRODUCT, including, without limitation, any damages, liabilities, costs or expenses incurred by reason of BUYER'S negligence related to those uses of the PRODUCT as a result of the removal of the PRODUCT.

SELLER assumes no liability regarding the improper installation or misapplication of the PRODUCT. It is the installer's responsibility to check for proper installation, and, if in doubt, contact the manufacturer.

LIMITATION OF WARRANTY

SELLER hereby provides the following limited warranty as to description, quality, merchantability, fitness for any product's purpose, productiveness, or any other matter of SELLER'S product sold herewith. The SELLER shall be in no way responsible for the product's open use and service and the BUYER hereby waives all rights other than those expressly written herein. This Warranty shall not be extended or varied except by a written instrument signed by SELLER and BUYER.

The Warranty is Limited to one (1) year from the date of sale and limited solely to the parts contained within the product's kit. All products that are in question of Warranty must be returned shipping prepaid to the SELLER and must be accompanied by a dated proof of purchase receipt. All Warranty claims are subject to approval by BD ENGINE BRAKE, Inc.

Under no circumstances shall the SELLER be liable for any labor charged or travel time incurred in diagnosis for defects, removal, or reinstallation of this product, or any other contingent expenses.

Under no circumstances will the SELLER be liable for any damage or expenses insured by reason of the use or sale of any such equipment.

IN THE EVENT THAT THE BUYER DOES NOT AGREE WITH THIS AGREEMENT: THE BUYER MAY PROMPTLY RETURN THIS PRODUCT, IN A NEW AND UNUSED CONDITION, WITH A DATED PROOF OF PURCHASE, TO THE PLACE OF PURCHASE WITHIN THIRTY (30) DAYS FROM DATE OF PURCHASE FOR A FULL REFUND. THE INSTALLATION OF THIS PRODUCT INDICATES THAT THE BUYER HAS READ AND UNDERSTANDS THIS AGREEMENT AND ACCEPTS ITS TERMS AND CONDITIONS.

BD Engine Brake, Inc.

Plant Address: Unit A10, 33733 King Rd, Abbotsford, BC, Canada V2S 7M9

U.S. Shipping Address: 88-446 Harrison St, Sumas, WA 98295 U.S. Mailing Address: P.O. Box 231, Sumas, WA 98295

Phone: 604-853-6096 Fax: 604-853-8749 Internet: www.bd-power.com