

EZ - Ride Suspension

PART NUMBER : 52901
1999 - CURR TOYOTA TUNDRA
1.5" - 2" FRONT LEVELING SYSTEM

PARTS LIST:

| Part # | Description | Qty. |
|-----------|----------------------|------|
| MO3271 | Front Strut Spacer | 2 |
| MO3273 | Front Strut Isolator | 2 |
| M10214B | 10 MM x 2 1/4" Stud | 6 |
| 52901INST | Instruction Sheet | 1 |

Special Note:

A strut compressor is going to be needed to perform this installation. If you do not have a strut compressor you may rent one from your local Auto Parts store.

Due to the inconsistencies of the stock strut, height after installation of the spacer may vary. Any questions please feel free to contact Tuff Country or your local Tuff Country dealer.

Congratulations on your selection to purchase a Tuff Country EZ-Ride Suspension System. We at Tuff Country are proud to offer a high quality product at the industries most competitive pricing. Thank you for your confidence in us, and our product.

Before installation begins, it is the customers/installers responsibility to make sure that all parts are on hand. If any parts are missing, please feel free to call one of our customer service representative @ (800) 288-2190.

Make sure to use locktite on all new and stock hardware associated with this installation.

Torque Settings

| | |
|-------|-----------------|
| 5/16" | 15—18 ft lbs. |
| 3/8" | 28—32 ft lbs. |
| 7/16" | 30—35 ft lbs. |
| 1/2" | 65—85 ft lbs. |
| 9/16" | 85—120 ft lbs. |
| 5/8" | 95—130 ft lbs. |
| 3/4" | 100—140 ft lbs. |

INSTALLATION MANUAL

1.5" - 2" FRONT LEVELING SYSTEM 1999 - CURR

TOYOTA TUNDRA

PART # 52901

SJ100302

IMPORTANT CUSTOMER INFORMATION

Tuff Country EZ-Ride Suspension highly recommends that a qualified and or certified mechanic performs this installation.

If you desire to return your vehicle to stock, it is the customers responsibility to save all stock hardware.

This vehicles reaction and handling characteristics may differ from standard cars and/or trucks. Modifications to improve and/or enhance off road performance may raise the intended center of gravity. Extreme caution must be utilized when encountering driving conditions which may cause vehicle imbalance or loss of control. **DRIVE SAFELY!** Avoid abrupt maneuvers, such as sudden sharp turns which could cause a roll over, resulting in serious injury or death.

It is the customers responsibility to make sure that a re-torque is performed on all hardware associated with this suspension system after the first 500 miles of installation. It is also the customers responsibility to do a complete re-torque after every 3000 miles or after every off road use.

After the original installation, Tuff Country EZ-Ride Suspension also recommends having the alignment check every 6 months to ensure proper tracking, proper wear on tires and front end components. Tuff Country EZ-Ride Suspension take no responsibility for abuse, improper installation or improper suspension maintenance.

It is the responsibility of the customer or the mechanic to wear safety glasses at all times when performing this installation.

It is the customers/installers responsibility to read and understand all steps before installation begins. OEM manual should be used as a reference guide.

The Tuff Country EZ-Ride Suspension product safety label that is included in your kit box must be installed inside the cab in plain view of all occupants.

It is the responsibility of the installers to make sure that the rear view mirror hanger is hung from the rear view mirror. The rear view mirror hanger has instructions on proper post installation procedure.

LIMITED LIFETIME WARRANTY

Notice to all Tuff Country EZ-Ride Suspension customers: It is your responsibility to keep your original sales receipt! If failure should occur on any Tuff Country EZ-Ride Suspension component, your original sales receipt must accompany the warranted unit to receive warranty. Warranty will be void if the customer can not provide the original sales receipt. Do not install a body lift in conjunction with a suspension system. If a body lift is used in conjunction with any Tuff Country EZ-Ride Suspension product, your Tuff Country EZ-Ride Suspension **WARRANTY WILL BE VOID.** Tuff Country Inc. ("Tuff Country") suspension products are warranted to be free from defects in material and workmanship for life if purchased, installed and maintained on a non-commercial vehicle; otherwise, for a period of twelve (12) months, from the date of purchase and installation on a commercial vehicle, or twelve thousand (12,000) miles (which ever occurs first). Tuff Country does not warrant or make any representations concerning Tuff Country Products when not installed and used strictly in accordance with the manufacturer's instructions for such installation and operation and accordance with good installation and maintenance practices of the automotive industry. This warranty does not apply to the cosmetic finish of Tuff Country products nor to Tuff Country products which have been altered, improperly installed, maintained, used or repaired, or damaged by accident, negligence, misuse or racing. ("Racing is used in its broadest sense, and, for example, without regards to formalities in relation to prizes, competition, etc.) This warranty is void if the product is removed from the original vehicle and re-installed on that or any other vehicle. This warranty is exclusive and is in lieu of any implied warranty of merchantability, fitness for a particular purpose or other warranty of quality, whether express or implied, except the warranty of title. All implied warranties are limited to the duration of this warranty. The remedies set forth in this warranty are exclusive. This warranty excludes all labor charges or other incidental of consequential damages. Any part or product returned for warranty claim must be returned through the dealer of the distributor from whom it was purchased. Tuff Country reserves the right to examine all parts returned to it for warranty claim to determine whether or not any such part has failed because of defect in material or workmanship. The obligation of Tuff Country under this warranty shall be limited to repairing, replacing or crediting, at its option, any part or product found to be so defective. Regardless of whether any part is repaired, replaced or credited under this warranty, shipping and/or transportation charges on the return of such product must be prepaid by the customer under this warranty.

For a list of all parts, please refer to the Parts Description Page, at the end of the Installation Manual.

Please Follow Instruction Carefully

Before installation begins, drive and check to make sure there are no uncommon sounds and or frame damage. Also at this time measure from the center of the hub to the bottom of the fender well and record measurements below.

Pre Installation Measurements:

Driver Side Front: _____

Passenger Side Front: _____

At the end of the installation take the same measurements and compare to the pre-installation measurements.

Post Installation Measurements:

Driver Side Front: _____

Passenger Side Front: _____

1. To begin installation, block the rear tires of the vehicle so that the vehicle is stable and can't roll backwards. Safely lift the front of the vehicle and support the frame with a pair of jack stands. Place a jack stand on both the driver and passenger side. Next, remove the wheels and tires from both sides.
 2. Working on the driver side, remove the stock sway bar hardware from the stock frame location and save the stock hardware for later re-installation. Repeat procedure on the passenger side. **Special Note: Tie the stock sway bar up and out of the way during installation.**
 3. Working on the driver side, remove the (3) upper stock nuts that connect the stock strut into the stock location. Save the stock nuts for later re-installation. Repeat procedure on the passenger side.
 4. Working on the driver side, remove the stock lower bolt that connects the lower stock mounting point to the stock lower strut. Remove the stock strut assembly and stock lower bolt and set a side for later re-installation. Repeat procedure on the passenger side.
- Special Note: A strut compressor is going to be needed to perform this installation. If you do not have a strut compressor you may rent one from your local Auto Parts store.**
5. Working on the driver side strut assembly that was removed from step # 4, carefully compress the stock strut using a strut compressor. **Special Note: Scribe a reference mark on the top of the stock strut nut. This**

will allow you to reinstall the stock nut back into the stock position. Remove the stock nut and hardware from the top of the stock strut assembly. Save the stock hardware for later re-installation.

6. Remove the stock upper strut bracket from the strut assembly. The stock rubber spacer may be discarded. Carefully remove the stock studs located in the stock upper strut bracket and discard the stock studs. **Special Note: Use of a hammer makes the removal of the stock studs easier.**
7. Locate (3) new 10 mm x 2 1/4" studs. Carefully install the new studs into the stock upper strut bracket that was removed from step # 6. **Special Note: Make sure that the new studs seat properly into the upper strut bracket.**
8. Locate (1) new strut isolator. Using a strut compressor, compress the stock strut enough so that the new strut isolator can be installed. Install the new strut isolator and secure the stock strut assembly and new strut isolator with the upper hardware that was removed from step # 5. Refer to the reference mark that was scribe in step # 5.
9. Locate the (3) stock upper studs nuts that were removed from step # 3. Working on the driver side of the vehicle, install the new upper strut spacer on top of the new strut assembly and install into the stock strut upper location. Secure the top of the new strut assembly using the stock hardware. Torque to the stock hardware to **42 ft lbs.**
See Illustration # 1
10. Repeat steps 5 - 9 on the passenger side.
11. Working on the driver side, remove the stock upper ball joint cotter pin and nut. Save for later re-installation. Carefully separate the upper ball joint from the stock spindle. **Special Note: Tuff Country EZ-Ride Suspension recommends using a ball joint separator or suitable tool.** Repeat procedure on the passenger side.
13. Locate the stock lower strut bolt and hardware that was removed from step # 4. Secure the new strut assembly into the stock lower location using the stock hardware. Torque to **85 ft lbs.** **Special Note: When installing the stock lower bolt, make sure that the bolt is installed the way it was removed. Facing towards the front of the vehicle.** Repeat procedure on the passenger side.
14. Working on the driver side, use a hydraulic floor jack, carefully raise up on the lower control arm and connect the upper ball joint on the upper control arm to the stock spindle. Secure the stock upper control arm to stock spindle using the stock hardware and cotter pin that was removed from step # 11. Repeat procedure on the passenger side.
15. Re-install the stock sway bar into the stock location and secure using the stock hardware that was removed from step # 2.
16. Re-install the tires and wheels and safely lower the vehicle to the ground.

Check and double check to make sure that all steps were performed properly. Once installation is complete take vehicle directly to an alignment center for proper front end alignment.

Congratulations Installation Complete

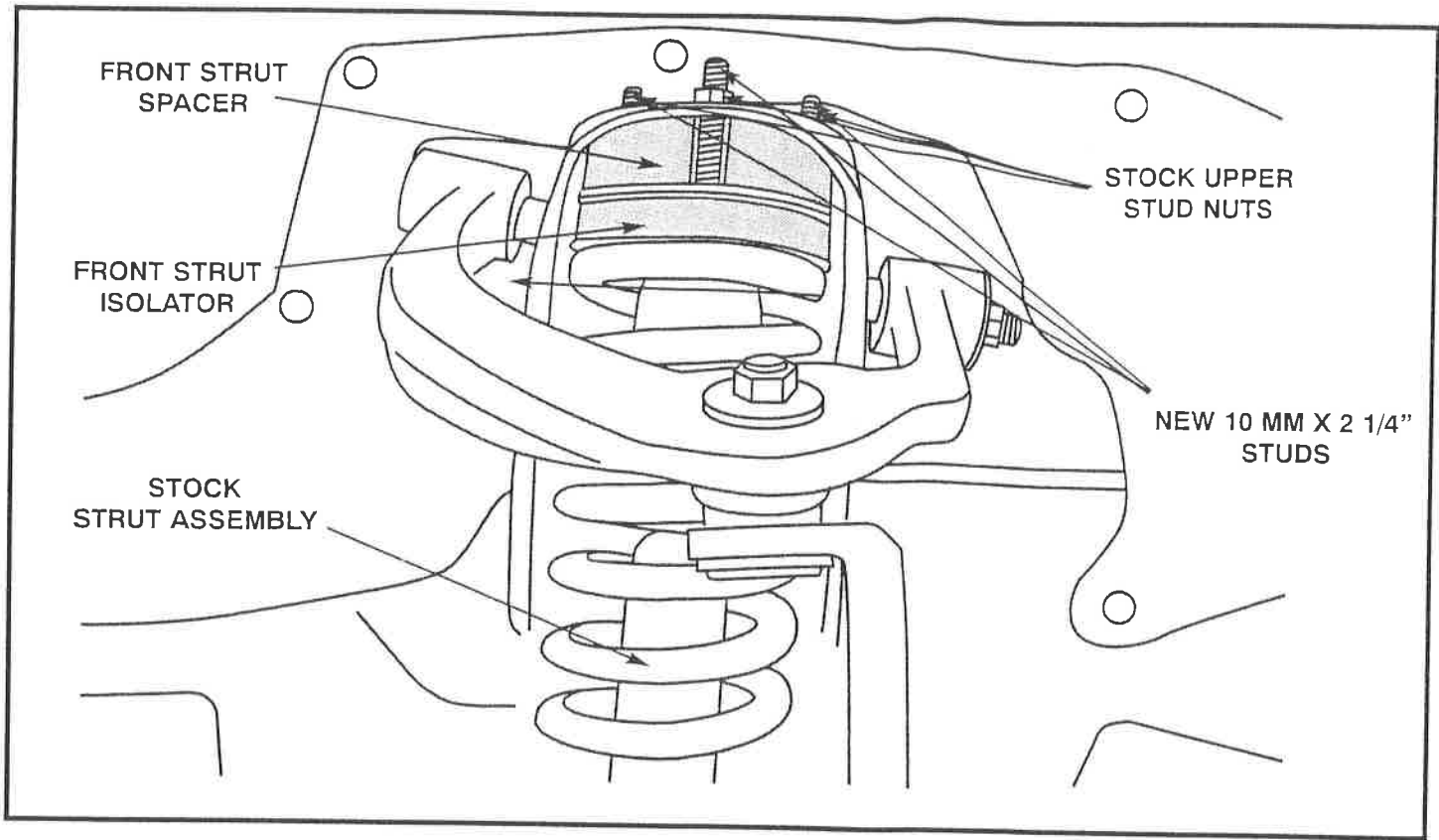

ILLUSTRATION # 1

