



TUFF COUNTRY

EZ-RIDE SUSPENSION

OLD PART #. ZJ035FX
 NEW PART # 43902
 JEEP GRAND CHEROKEE 3.5"
 SUSPENSION LIFT WITH EZ FLEX ARMS
 PARTS LIST:

Qty.	Description	Part No.
2	Front Coil Springs	ZJ035FCL01
2	Rear Coil Springs	ZJ035RCL01
4	Front and Rear EZ Flex Control Arms	TJ3A
1	Hardware Bag	TJ4-NB
1	Front Track Bar Bracket	TJ4-01
1	Rear Track Bar Bracket	TJ4-02
1	Front Track Bar Sleeve	15-204
1	Rear Track Bar Sleeve	916114SL
1	Rear Brakeline Extension	BLR03
2	Front Brakeline Extension	BLR05
2	Shock Mounts	BP07
1	Instruction Sheet	ZJ035FXINST

Congratulations on your selection to purchase a Tuff Country Suspension System. We at Tuff Country are proud to offer a high quality product at the industries most competitive pricing. Thank you for your confidence in us, and our product.

***Important Notes:** Please read before beginning installation. OEM Manual should be used as a reference.

TUFF COUNTRY SUSPENSION highly recommends a qualified and or certified mechanic to perform this installation.

Check off parts list to be sure all parts are on hand. If any part is missing, you may call Tuff Country at: (800) 288-2190.

Read and understand all sections of instruction manual. Use locktite on all bolts associated with this installation.

Product safety label must be installed inside the cab in plain view of all occupants.

Torque Settings:

5/16"	15-18 ft. lbs.	3/8"	28-32 ft.lbs.
7/16"	30-35 ft. lbs.	1/2"	65-85 ft. lbs.
9/16"	75-90 ft. lbs	5/8"	85-110 ft. lbs.
3/4"	105-125 ft. lbs.		

INSTALLATION MANUAL

3.5" SUSPENSION LIFT

1992 - 1998 JEEP GRAND CHEROKEE
 NEW PART # 43902 / OLD PART # ZJ035FX

SJ021601

WARNING: TUFF COUNTRY EZ-RIDE SUSPENSION HIGHLY RECOMMENDS THAT A CERTIFIED MECHANIC PERFORMS THIS INSTALLATION.

WARNING

If you desire to return vehicle to stock make sure to save all stock components.

IMPORTANT CUSTOMER INFORMATION

This vehicle's reaction and handling characteristics may differ from standard cars and/or trucks. Modifications to improve and or enhance off road performance may raise the intended center of gravity. Extreme caution must be utilized when encountering driving conditions which may cause vehicle imbalance or loss of control. Drive Safely! Avoid abrupt maneuvers, such as sudden sharp turns, which could cause a roll over, resulting in serious injury or death.

It is the customer's responsibility to make sure a re-torque is performed on all hardware associated with this suspension system after the first 100 miles of installation. It is also the customer's responsibility to do a complete re-torque after every 1000 miles or after every off road use.

After the original installation, Tuff Country also recommends having the alignment checked every 6 months to ensure proper tracking, proper wear on tires and front end components. Tuff Country takes no responsibility for abuse, improper installation, or improper suspension maintenance.

IMPORTANT NOTICE

DO NOT install a body lift in combination with a suspension system. If a body lift is used in conjunction with any Tuff Country Suspension product, your Tuff Country WARRANTY WILL BE VOID.

NOTICE

It is the responsibility of the customer or the mechanic to wear safety glasses at all times when working with air tools.

Please Follow Instruction Carefully

Before installation begins, drive and check to make sure there are not any uncommon sounds and or frame damage. Also at this time measure from the center of the hub to the bottom of fender well and record measurements below.

Pre Installation Measurements:

Driver Side Front _____
Passenger Side Front _____
Driver Side Rear _____
Passenger Side Rear _____

At the end of the installation take the same measurements and compare to the pre installation measurements.

Post Installation Measurement:

Driver Side Front _____
Passenger Side Front _____
Driver Side Rear _____
Passenger Side Rear _____

Front End Installation:

1. To begin installation, block the rear tires of the vehicle so that the vehicle is stable and can't roll backwards. Safely lift the front of the vehicle and support the stock frame with a pair of jack stands. Place a jack stand on both the driver and the passenger side. Next, remove the wheels and tires from both sides.

2. On the driver side, locate the top of the shock absorber stud in the engine compartment. Remove the stock nut, retainer washer and grommet. **Special Note: Some Jeep Grand Cherokee's has a variation on the stock grommet sizes, save the stock grommets, they may need to be re-installed.** Repeat procedure on passenger side.

3. Working on the driver side, remove the stock lower bolts that hold the stock shock bar pin to the stock location and save hardware for later re-installation. **Special Note: New shock bar pins are included in this suspension system, the stock bar pins my be discarded.** Repeat procedure on passenger side.

4. Working on the driver side, remove the stock bolt that holds the stock brakeline bracket to the inner frame rail. Save the stock bolt for later re-installation. Repeat procedure on passenger side

5. Position a pair of hydraulic floor jacks under the front axle, place one on the driver side and one on the passenger. Raise up on the hydraulic floor jacks at the same time until they come into contact with the front axle.

6. Working on the driver side, un-bolt the stock sway bar at the axle location, save hardware for later re-installation. Repeat procedure on passenger side.

7. Working on the passenger side of the vehicle, remove the stock track bar bolt that connects the stock track bar to the stock track bar bracket. Save hardware for later re-installation.

8. If the vehicle that you are working on has a stock steering stabilizer, remove the stock stabilizer bolt from the passenger side axle location. Save hardware for later re-installation.

9. On the driver side, locate the stock lower control arm. On the front mounting bracket scribe a mark on the stock alignment cam and reinforcement bracket. This is done for a later installation reference. Repeat procedure on passenger side.

10. Working on the driver side, remove the front stock lower control arm from the stock mounting points and save hardware for later re-installation. Stock front lower control arm may be discarded, new front EZ flex lower control arms are provided with this suspension system. Repeat procedure on passenger side.

11. Working on the driver side, remove the stock coil spring clip at the bottom of the stock coil spring. Save the stock clip and hardware for later re-installation. Repeat procedure on passenger side.

12. Lower down on both hydraulic floor jacks at the same time until the stock coil springs separate from the stock location. Lower down enough so that the stock coil springs can be removed. Remove both the driver and the passenger side stock coil springs and discard.

13. Locate (2) new front coil springs. Working on the driver side, install the new coil spring into the stock location. Repeat procedure on passenger side.

14. Raise up on both hydraulic floor jacks at the same time until the new coil springs seat properly into the stock location.

15. Locate (2) new EZ flex control arms. Compare the stock rear lower control arms that were removed in step # 10 to the new EZ flex control arms. Adjust the new EZ flex control arms so that they are the same length as the stock front lower control arms. Then adjust the new EZ flex control arm out one full turn. **Special Note: Once this is done, your eye to eye measurement on the new EZ flex control arms should measure out at 15 15/16" long.**

See Illustration # 1

16. Working on the driver side, install the new EZ flex front lower control arm into the stock front mounting point. Secure using the stock hardware that was removed in step # 10. **Do not tighten at this point.** Next, install the rear eyelet of the new EZ flex front lower control arm into the stock rear

mounting point. Secure using the stock hardware that was removed from step # 10. **Do not tighten at this point.** **Special Note: When installing the new EZ flex front lower control arms into the stock location make sure to install the new EZ flex arms with the sert fitting facing upwards. This is done so that the sert fitting will not be damaged during off road use. Also slight prying of the stock control arm mounts may be needed to make installation easier. Also raising the axle to ride height and moving it slightly up and down will also make installation easier.** Repeat procedure on passenger side.

See Illustration # 2

17. Locate the new front track bar relocating bracket, from hardware bag labeled TJ4-NB locate (1) 10mm x 3" bolt, (1) 10 mm lock nut, (1) 3/8" x 1" bolt, (1) 3/8" unitorque nut and (4) 3/8" flat washers. Also locate (1) 15.204 front track bar anti crush sleeve. Working on the passenger side axle location, install the new front track bar relocation bracket into the stock track bar location with the open end of the new bracket facing downward. Install the new anti crush sleeve into the upper stock hole of the new front track bar bracket. Secure using stock hardware that was removed in step # 7. **Do not fully tighten at this point.**

See Illustration # 3

18. Using the new front track bar relocation bracket as a guide, drill a 3/8" hole into the back side of the stock track bar bracket and secure the new track bar relocation bracket to the stock track bar bracket using the new 3/8" x 1" bolt and hardware. Tighten the 3/8" bolt to **30 ft. lbs.**

See Illustration # 3

19. Next, install the stock track bar to the newly installed front track bar relocation bracket and secure using the new 10 mm x 3" bolt and hardware. Torque the stock upper bolt on the new front track bar relocation bracket and the new 10 mm bolt to **28 ft. lbs.** **If you are not able to line up the hole in the stock track bar and the new track bar relocation bracket, the weight of the vehicle may need to be on the ground, if this is the case, perform this step once the vehicle is lowered to the ground.**

See Illustration # 4

20. Locate (2) new front brakeline relocation brackets, from hardware bag labeled TJ4-NB locate (2) 1/4" x 3/4" bolts, (4) 1/4" washers and (2) 1/4" unitorque nuts. Working on the driver side, install the new brakeline relocation bracket to the stock brakeline bracket and secure using new 1/4" x 3/4" bolt and hardware. Torque to **8 ft. lbs.** Next, install the new brakeline relocation bracket to the stock location and secure using the stock hardware that was removed in step # 4. Repeat procedure on passenger side.

See Illustration # 5

21. Make sure that the new coil springs are seated properly into the stock location. Working on the driver side, re-install the stock coil spring clip and hardware that was removed in step # 11. Repeat procedure on passenger side.

22. Working on the driver side, torque the front stock

mounting bolt that holds the new EZ flex front lower control arm to the stock location to **85 ft. lbs.** **Special Note: Make sure that the stock alignment cam is set to the stock setting. Refer to the marks that were scribed on the stock alignment cam and reinforcement bracket in step # 9.** Repeat procedure on passenger side.

23. Working on the driver side, torque the rear stock bolt on the new EZ flex front lower control arm to **85 ft. lbs.** Repeat procedure on passenger side.

24. Carefully remove both hydraulic floor jacks from under the vehicle.

25. Working on the driver side, re-install the stock sway bar to the stock axle location and secure using the stock hardware that was removed from step # 6. **Special Note: If you are not able to re-install the stock sway bar to the stock sway bar mount, you will have to perform this step once the weight is on the vehicle.** Repeat procedure on passenger side.

26. Locate the new front shocks. **(Shock are not include with this suspension system, shocks need to be ordered as a separate part number, Tuff Country recommends using a 23" fully extended hydraulic shock).** Locate the new lower front shock bar pins. **(Included with this suspension system)** Install the new bushings into the lower eyelet of the new shocks. **Special Note: Make sure to use a lithium or moly base grease prior to inserting the new bushings into the new shocks. This will increase the life of the bushing as well as prevent squeaking.** Next, install the new bar pin into the newly installed poly bushing.

27. Working on the driver side, install the new front shock into the stock location. Secure the lower bar pin into the stock location and secure using the stock hardware that was removed in step # 3. Torque to **8 ft. lbs.** Repeat procedure on passenger side.

28. Install the new upper shock grommets to the new front shocks. **Special Note: Some Jeep Grand Cherokee's has a variation on the stock grommet sizes, if the new grommets are to small the stock grommets may need to be re-installed.** Working on the driver side, install the upper stud into the stock location and secure using the stock hardware. Repeat procedure on passenger side.

29. Re-install the stock stabilizer to the passenger side location and secure using the stock hardware that was removed from step # 8.

30. Check and double check to make sure that all steps were performed properly. Check and double check to make sure that all new and stock hardware is torque to proper specifications. Refer to the torque settings on the front cover of your installation manual.

31. Install the tires and wheels and safely lower the vehicle to the ground.

32. **If you were not able to line up the stock track bar and the newly installed track bar relocation bracket from step # 19. Perform step # 19 at this point.**

33. **If you were not able to re-connect the stock sway bar to the stock sway bar mounting point in step # 25. Perform step # 25 at this point.**

Front End Installation Complete:

Rear End installation:

34. To begin installation, block the front tires of the vehicle so that the vehicle is stable and can't roll forward. Safely lift the rear of the vehicle and support the stock frame with a pair of jack stands. Place a jack stand on both the driver and the passenger side. Next, remove the wheels and tires from both sides.

35. Position a pair of hydraulic floor jacks under the rear axle, place one on the driver side and one on the passenger side. Raise up on the hydraulic floor jacks at the same time until they come into contact with the rear axle.

36. Working on the driver side, remove the stock shock and discard. Save the stock hardware for later re-installation. Repeat procedure on passenger side.

37. Working on the driver side, remove the stock rear sway bar from the frame location and save hardware for later re-installation. Repeat procedure on passenger side.

38. Working on the driver side, remove the stock rear track bar from the stock location and save hardware for later re-installation. Repeat procedure on passenger side. Also at this time remove the plastic cover off the driver side track bar bracket. The plastic cover may be discarded.

39. Working on the driver side, remove the rear stock lower control arm from the stock mounting points and save hardware for later re-installation. The stock rear lower control arm may be discarded, new rear EZ flex lower control arms are provided with this suspension system. Repeat procedure on passenger side.

40. Working on the driver side, remove the stock coil spring clip at the bottom of the stock coil spring. Save the stock clip and hardware for later re-installation. Repeat procedure on passenger side.

41. Lower down on both hydraulic floor jacks at the same time until the stock rear coil springs separate from there stock location. Lower down enough so that the stock coil springs can be removed. Remove both the driver and the passenger side stock coil spring and discard.

42. Locate (2) new rear coil springs. Working on the driver side, install the new rear coil spring into the stock location. Repeat procedure on passenger side.

43. Raise up on both hydraulic floor jacks at the same time until the new rear coil springs seat properly into the stock

location.

44. Locate (2) new EZ flex control arms. Compare the stock rear lower control arms that were removed in step # 39 to the new EZ flex control arms. Adjust the new EZ flex control arms so that they are the same length as the stock rear lower control arms. Then adjust the new rear EZ flex control arm out one full turn. **Special Note: Once this is done, your eye to eye measurement on the new EZ flex control arm should measure out at 16 3/4" long.**

See Illustration # 6

44. Working on the driver side, install the new rear EZ flex lower control arm into the stock mounting point on the rear axle. Secure using the stock hardware that was removed in step # 39. **Do not tighten at this point.** Next, install the front eyelet of the new rear EZ flex lower control arm into the stock frame mounting point. Secure using the stock hardware that was removed from step # 39. **Do not tighten at this point. Special Note: When installing the new rear EZ flex lower control arms into the stock location make sure to install the new EZ flex arms with the sert fitting facing upwards. This is done so that the sert fitting will not be damaged during any off road use. Also slight prying of the stock control arm mount may be needed to make installation easier. Also raising the axle to ride height and moving it slightly up and down will also make installation easier.** Repeat procedure on passenger side.

See Illustration # 7

45. Locate the new rear track bar relocation bracket, (1) 12 mm x 3" bolt, (1) 12 mm lock nut, (2) 5/16" x 1" bolt, (2) 5/16" unitorque nuts, (4) 5/16" flat washers, (2) 7/16" flat washers and (1) rear track bar anti crush sleeve. Install the new rear track bar relocation bracket over the driver side stock rear track bar bracket and secure using the stock hardware and new anti crush sleeve into the stock location. **Do not tighten at this point.**

See Illustration # 8

46. Using the new bracket as a guide, drill a 5/16" hole in the bottom and the top of the stock track bar bracket. Secure using the new 5/16" x 1" bolt and hardware. **Torque to 18 ft lbs. Special Note: Some Jeep Grand Cherokee's have a variation in the stock rear track bar bracket, if the new rear track bar relocation bracket does not seat flush with the bottom of the stock track bar bracket, the new rear track bar bracket may need to be slightly bend to fit properly.**

See Illustration # 8

47. Working on the driver side, install the stock rear track bar into the newly installed track bar relocation bracket and secure using the new 12 mm x 3" bolt and hardware. Torque to **45 ft lbs.**

See Illustration # 9

48. Working on the passenger side, install the stock rear track bar into the stock location and secure using the stock hardware that was removed in step # 38. **Special Note: If**

you are not able to line up the hole in the stock track bar and the stock track bar bracket on the passenger side, the weight of the vehicle may need to be on the ground, if this is the case perform this step once the weight of the vehicle is on the ground.

49. Working on the driver side, torque the stock hardware that holds the new EZ flex rear lower control arm into the stock location to **85 ft. lbs.** Repeat procedure on passenger side.

50. Make sure that the new rear coil springs are seated properly into the stock location. Working on the driver side, re-install the stock coil spring clip and hardware that was removed in step # 40. Repeat procedure on passenger side.

51. Safely remove both hydraulic floor jacks from under the vehicle.

52. Locate the new rear shocks. **(Shock are not include with this suspension system, shocks need to be ordered as a separate part number, Tuff Country recommends using a 26" fully extended hydraulic shock).** Install the poly bushings in the upper and lower eyelets of each shock. **Special Note: Make sure to use a lithium or moly base grease prior to inserting the new bushings into the new shocks. This will increase the life of the bushing as well as prevent squeaking.** Working on the driver side, install the new shock to the upper and lower stock location and secure using the stock hardware. Repeat procedure on the passenger side.

53. Working on the driver side, re-install the stock sway bar to the stock frame location and secure using the stock hardware that was removed in step # 37. **Special Note: If you are not able to re-install the stock sway bar to the stock sway bar mount, you will have to perform this step once the weight is on the vehicle.** Repeat procedure on passenger side.

54. Check and double check to make sure that all steps were performed properly. Check and double check to make sure that all the new and stock hardware is torque to proper specifications. Refer to the torque settings on the front cover of your installation manual.

53. Install the tires and wheels and safely lower the vehicle to the ground.

53. If you were not able to line up the stock track bar and the newly installed track bar relocation bracket from step # 48 Perform step # 48 at this point.

54. If you were not able to re-connect the stock sway bar to the stock sway bar mounting point in step # 53, perform step # 53 at this point.

Check and double check to make sure that all steps were performed properly. Check and double check to make sure that all hardware is torqued to the proper specification. Refer to the torque settings on the front page of the installation manual.

CONGRATULATIONS INSTALLATION COMPLETE.

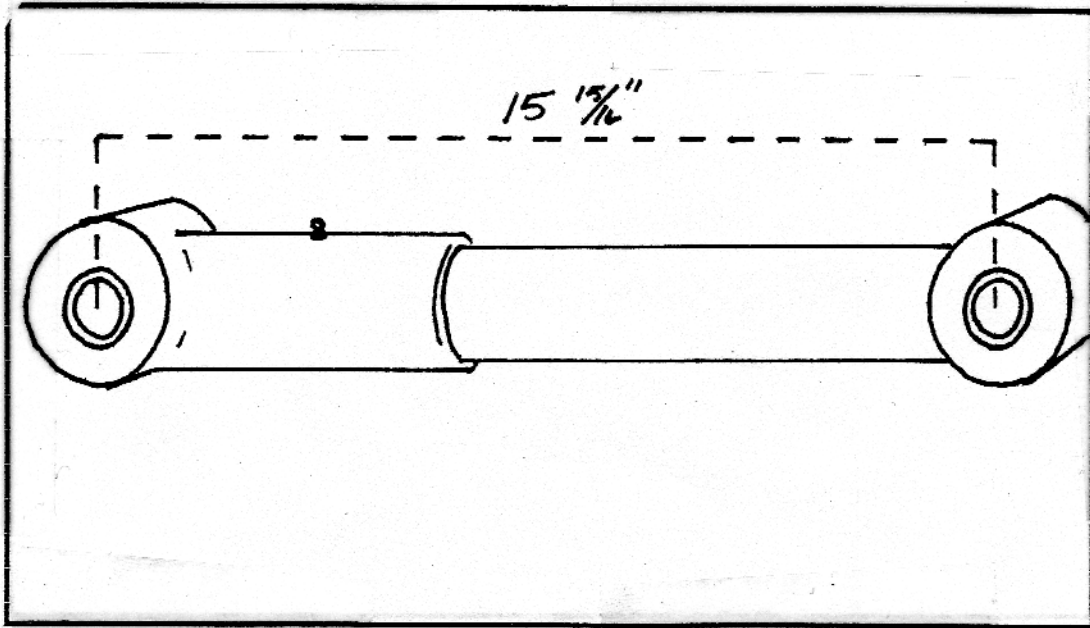

ILLUSTRATION # 1

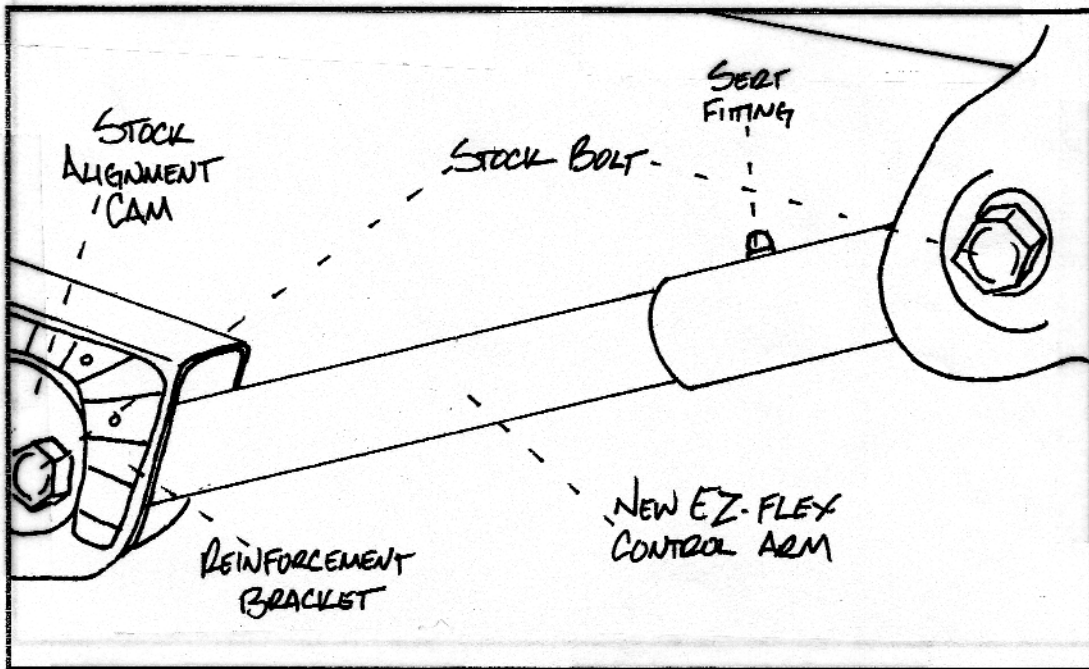

ILLUSTRATION # 2

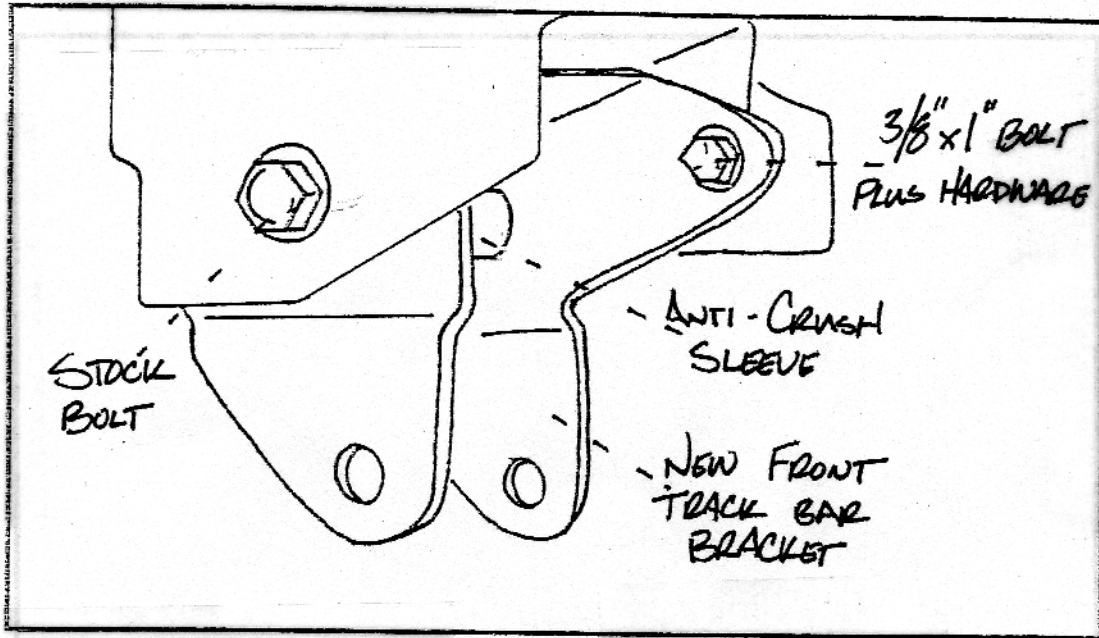

ILLUSTRATION # 3

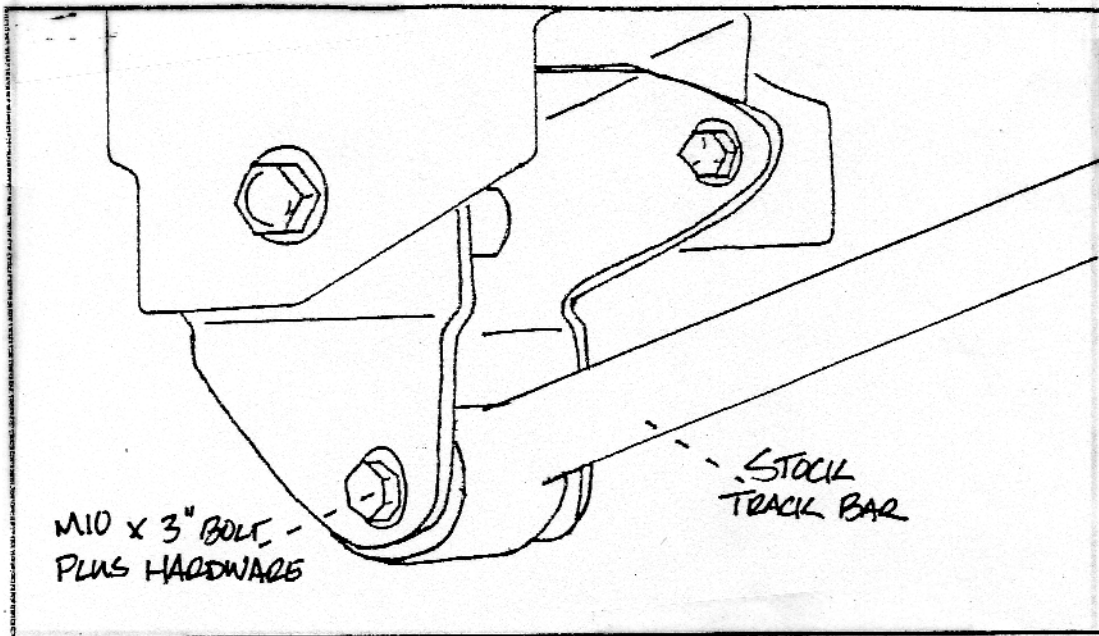

ILLUSTRATION # 4

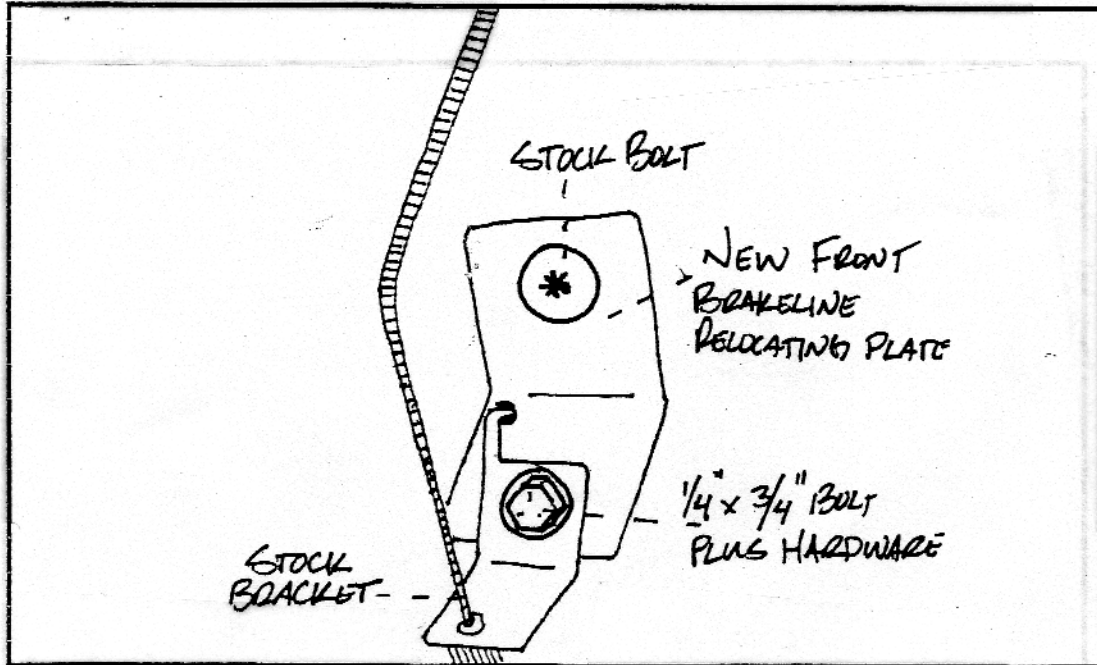

ILLUSTRATION # 5

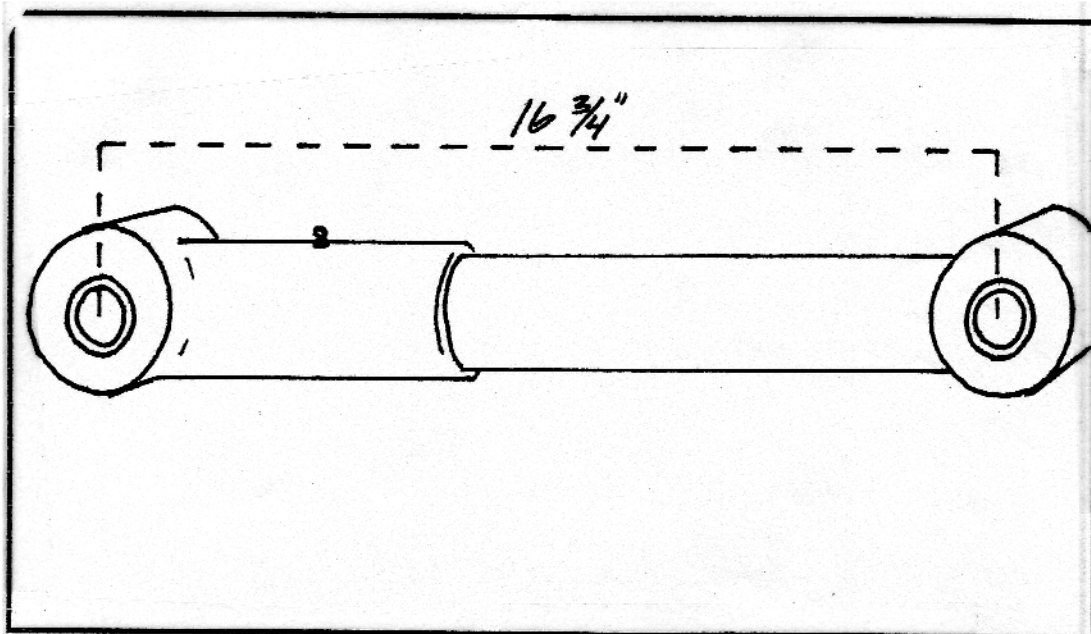

ILLUSTRATION # 6

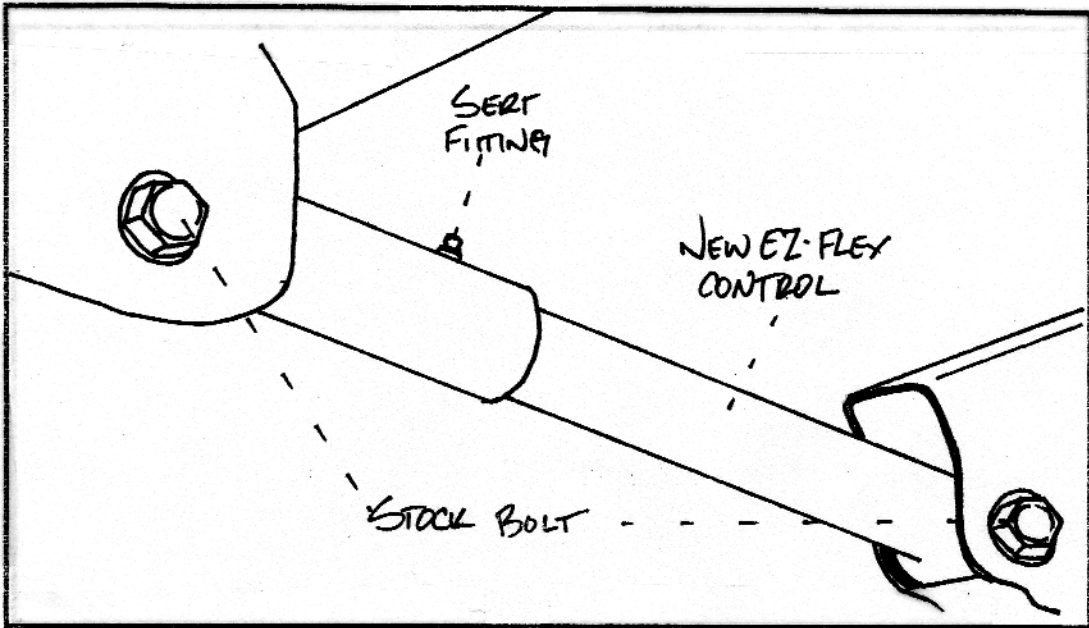

ILLUSTRATION # 7

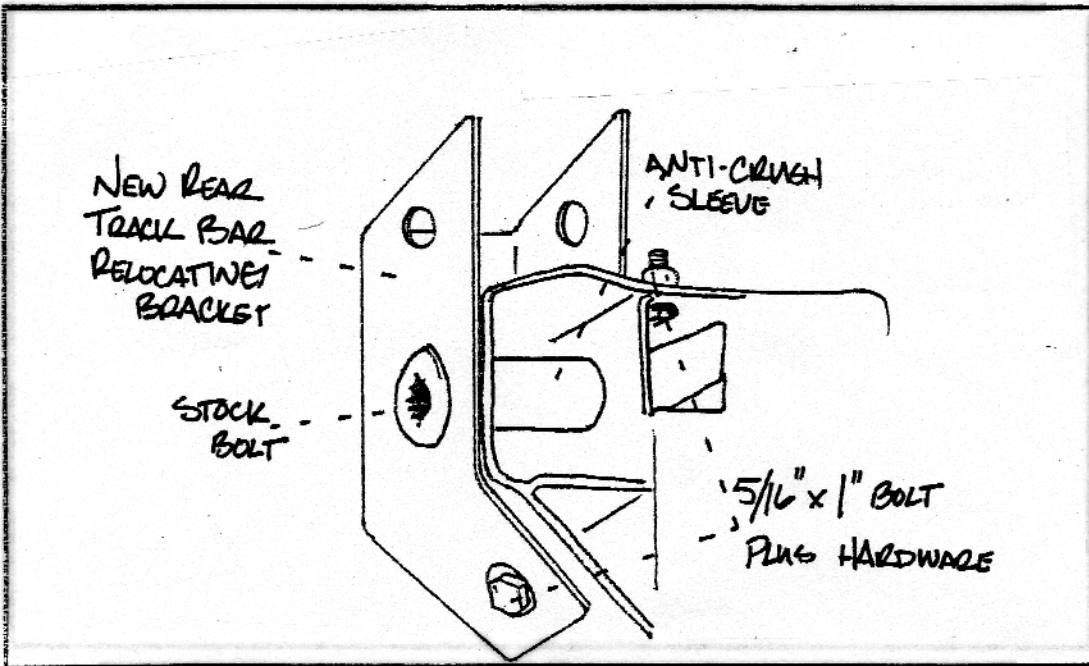

ILLUSTRATION # 8

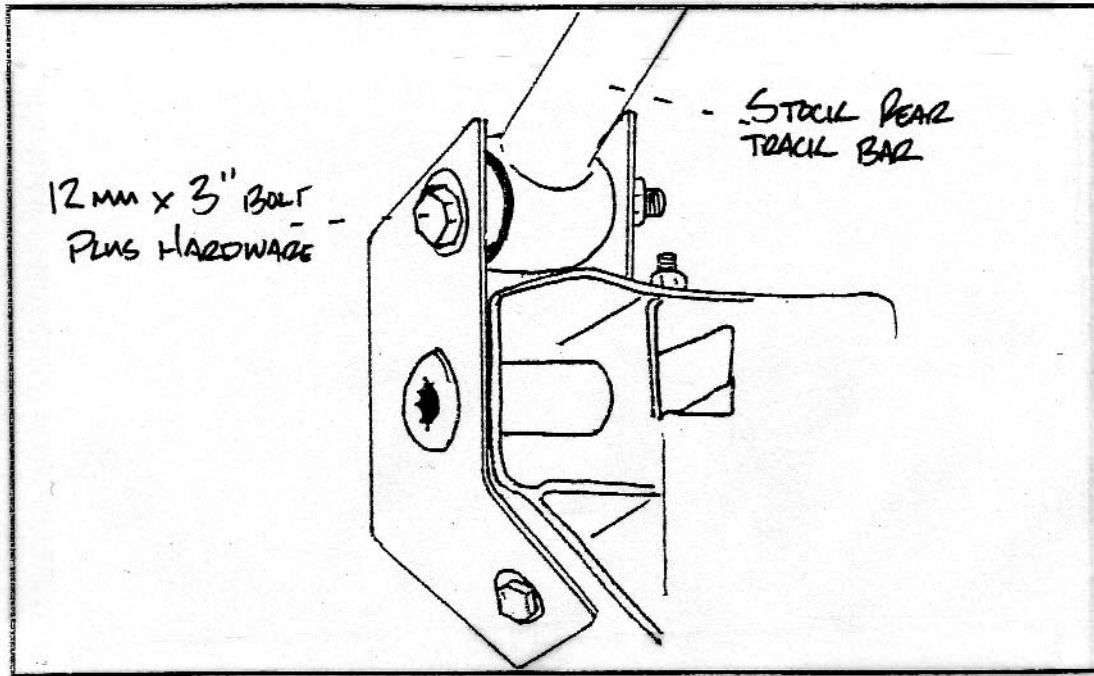

ILLUSTRATION # 9