

## Air System Monitor Kit

### INSTALLATION INSTRUCTIONS

Congratulations on your purchase of a new Air Gauge Accessory kit. This kit was designed to allow you to monitor the air pressure in your air helper springs from inside the vehicle's cab. Please take a few minutes to read through the instructions, identify the components, and learn how to properly install your Air Gauge Accessory kit.

#### NOTE:

The Air Gauge Accessory kit can be used with all air helper spring products. If you are installing an air suspension system, do not install the air line tubing to the air springs as stated in the suspension system instruction manual. If you are adding the Air Gauge Accessory kit to an existing air suspension system, you will need to deflate the air springs and splice into the air line tubing.

#### NOTE ON USING PUSH-TO-CONNECT AIR FITTINGS:

Cut the air line tubing as squarely as possible. To connect the air line tubing to the fittings, push the tubing into the fittings as far as possible. If for any reason the tubing must be removed, first release the air pressure from the air helper spring. Push the collar toward the body of the fitting and the pull out the tubing. To reassemble, make sure the tubing is cut squarely and push the tubing back into the fitting.

#### TOOLS REQUIRED:

POWER DRILL	WIRE CRIMPER/STRIPPER
5/16" DRILL BIT	PHILLIPS SCREW DRIVER
3/16" DRILL BIT	3/8" OPEN-END WRENCH
UTILITY KNIFE	PLIERS

#### PARTS LIST

GAUGE PANEL	1
18 FT. AIR LINE TUBING	1
NYLON TIE	6
BARBED T-FITTING	2
10 -32 X 1" MACHINE SCREW	2
10 -32 LOCK NUT	2
#10 FLAT WASHER	4
RING TERMINAL	1
WIRE CONNECTOR	1

### STEP 1—SELECT A MOUNTING LOCATION FOR THE GAUGE PANEL

Begin by removing the negative battery cable. Select a mounting surface under the dashboard or other protected location. Using the control panel as a template, mark each of the mounting points with a center punch. Drill a 3/16" diameter hole on each center mark *see Figure "A"*. Do not attach the control panel at this time.

### STEP 2—ROUTE THE AIR LINE TUBING

Before attaching the air line tubing to the gauge panel, soak the end of the air line (1") in warm water for a few minutes to soften the tubing. Install the air line tubing onto the barbed fitting on the back of the gauge panel. Do not use pliers to work the tubing onto the barbed fitting, as the tubing may be damaged.

Route the opposite end of the air line tubing to the end of the vehicle where the air springs are installed, avoiding direct heat from the engine, exhaust system, and away from sharp edges *see Figure "B"*. It may be necessary to drill a hole in the firewall to route the tubing. Ensure that the tubing is protected from sharp edges when passing through the firewall. **Do not fold or kink the tubing.** Secure the air line to the vehicle using the supplied nylon ties.

Install a barbed T-fitting on the end of the air line as described above *see Figure "B"*. Route the air line from each air spring to the barbed T-fitting. Attach the air line tubing from the air springs to the barbed T-fitting as noted above.

### STEP 3—INSTALL THE MANUAL INFLATION VALVE

Cut the air line tubing in a convenient location between the barbed T-fitting and the gauge panel. Soak the ends of the tubing (1") in warm water for a few minutes to soften the tubing. Install both ends onto a second barbed T-fitting *see Figure "B"*. Do not use pliers to work the tubing onto the barbed fitting, as the tubing may be damaged.

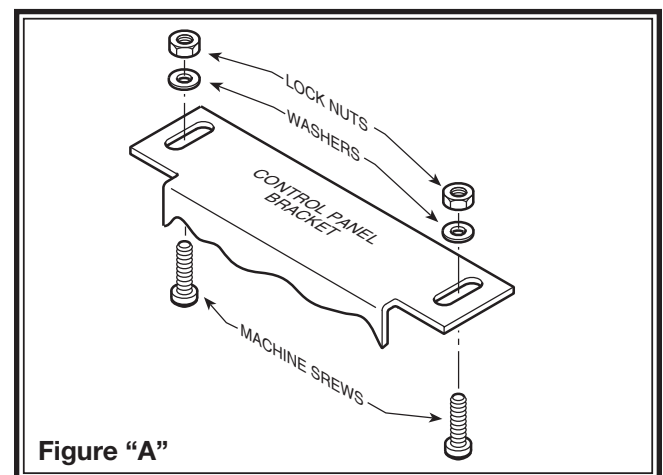
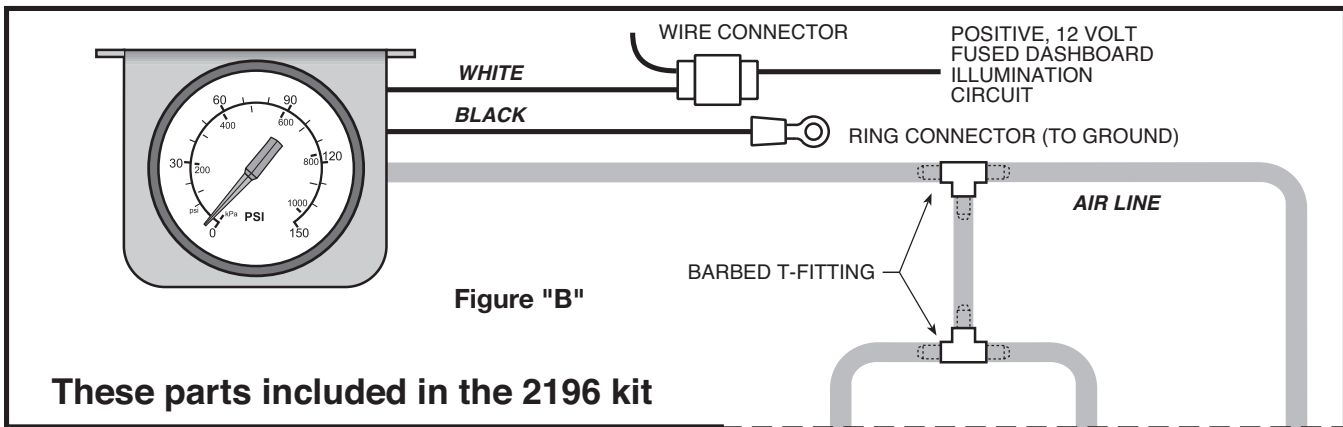

Figure "A"



Select a location on the vehicle for the manual inflation valve. The location can be on the bumper or the body of the vehicle, as long as it is in a protected location so the valve will not be damaged, but maintain accessibility for the air chuck. Drill a 5/16" hole and install the air inflation valve using two 5/16" flat washers per valve as supports *see Figure "C"* manual inflation valve. Route the tubing from the manual inflation valve to the T-fitting, avoiding direct heat from the engine, exhaust pipe, and away from sharp edges. Install the air line tubing on the barbed T-fitting as noted above.

**STEP 4—ATTACH THE GAUGE PANEL TO THE DASHBOARD**

Place the gauge panel on the dashboard where the holes were drilled in Step 1. Using the provided machine screws, nylon-insert hex nuts, and washers, attach the gauge panel to the dashboard or other selected mounting surface *see Figure "A"*.

**STEP 5—WIRE THE GAUGE PANEL FOR ILLUMINATION**

Attach the end of the positive wire (white) to a dashboard illumination wire using a wire connector. Slip the wire connector over the existing dashboard illumination wire and insert the gauge panel wire into the wire connector. Close the wire connector on to the wires with pliers *see Figures "B" & "E"*. Attach the negative wire (black) to a ground source by crimping a ring connector on to the wire and securing it to a suitable ground source on the vehicle *see Figure "D"*. **Note:** Should additional wire be necessary to reach the dashboard illumination wire and ground source, use 18 gage multi-strand wire.

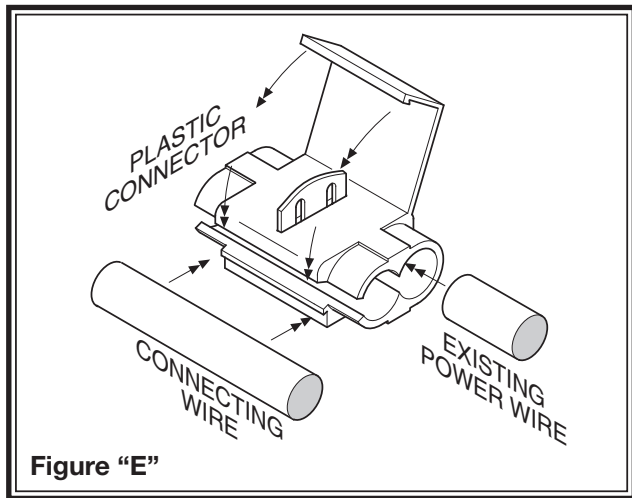
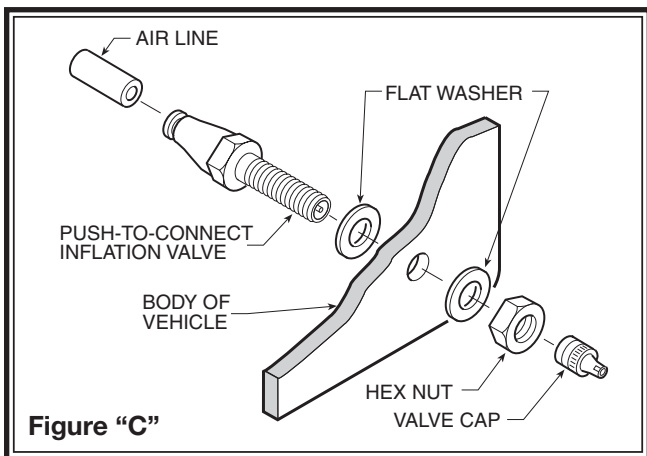
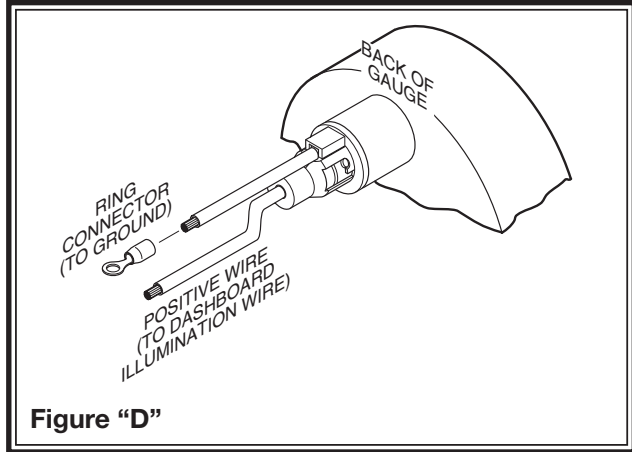
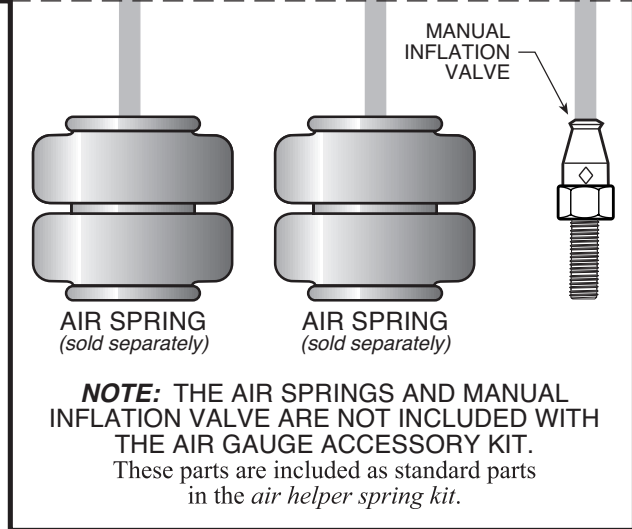



# Do Not Return This Product to the Dealer or Distributor

## If you are

- missing parts,
- experiencing installation problems, or
- have technical concerns regarding this product,

you may contact a Firestone Technical Service Representative at [rrtech@fsip.com](mailto:rrtech@fsip.com) or at 800-888-0650 (option 1, and then option 2). Representatives are available from 7:30 a.m. – 4:30 p.m. Eastern on Monday – Friday, excluding holidays. If you are located outside of the United States, you should first contact your distributor or dealer directly with any issues.

When contacting Technical Service, please have the kit or part # ready, along with the make, model, and year of the vehicle. You may also need to provide details, such as 2WD/4WD or if the vehicle has been lifted or lowered from stock height.

If you have a warranty concern, please include in your email a detailed description of the situation, a photo(s) of the issue, and your contact information, including ship-to address.

**WARRANTY COVERAGE\***— The Ride-Rite™ kits, components, and accessories are warranted against defects in workmanship and materials. This warranty does not cover service or labor charges, neglect...to the product.

### **PERIOD OF COVERAGE:**

- |   |  |
|---|--|
| • Ride-Rite air springs – Lifetime Limited  | • Work-Rite load assists – 2 Years Limited                                       |
| • Sport-Rite air springs – Lifetime Limited | • Air-Rite accessories – 2 Years Limited   |
| • Coil-Rite air springs – Lifetime Limited  | • Brackets, hardware, fittings, air line, and other components – 2 Years Limited |
| • Level-Rite air springs – Lifetime Limited |  |

**HOW TO MAKE A WARRANTY CLAIM** — If you purchased your air springs in the U.S. or Canada and believe you have a part with a warrantable defect, call Firestone directly at 1-800-888-0650.

International customers should contact their distributors or dealers directly with any problems.

(\*) Please refer to the “Firestone Limited Lifetime Air Spring Warranty” for details, terms, and conditions.

## **WARRANTY QUESTIONS**

Go to [www.riderite.com/installation-support](http://www.riderite.com/installation-support)  
Select “Warranty Info” tab